

ORO LOMA SANITARY DISTRICT

2655 GRANT AVENUE, SAN LORENZO, CA 94580



STANDARDS

REVISED NOVEMBER 2024

General Manager:

Jimmy T. Dang

District Engineer:

William D. Halsted

RCE # 68475

TABLE OF CONTENTS

<u>STANDARD</u>	<u>PAGE</u>
INTRODUCTION	1
DEFINITIONS AND ABBREVIATIONS	2
SEWER PIPE LINE	4
MHS AND CASTINGS.....	6
PORTLAND CEMENT CONCRETE AND GROUT	9
SEWER CONSTRUCTION AND REPAIR.....	11
TESTING.....	17
CLEANING	20
TELEVISION INSPECTION (PUBLIC SEWERS).....	21
SITE CLEANUP AND RESTORATION (PUBLIC SEWERS).....	22

STANDARD DETAILS

MAIN MH	SD-1
NOT USED	SD-2
INSIDE DROP MAIN MH.....	SD-3
TRUNK MH.....	SD-4
SHALLOW MAIN MH	SD-5
TYPE "A" SHALLOW MAIN MH	SD-6
PUMPED SYSTEMS	SD-7
24-inch MH FRAME AND COVER	SD-8
24-inch MH LOCKING FRAME AND COVER	SD-9
36-inch MH FRAME AND COVER	SD-10
BUILDING SEWER CLEANOUT TO GRADE	SD-11
CONCRETE ENCASEMENT/CAP	SD-12
SANITARY SEWER STORM DRAIN CROSSINGS	SD-13
UTILITY CROSSING	SD-14
BUILDING SEWER/BACKWATER PREVENTION SYSTEM.....	SD-15
TYPICAL TRENCH.....	SD-16
PRIVATE SEWER DISCONNECT DETAILS.....	SD-17
MH MODIFICATIONS	SD-18
MH PAD WITH RETAINING WALL	SD-19
PIPE REPLACEMENT THROUGH EXISTING MH	SD-20
FALSE BOTTOM.....	SD-21
GRIT TRAP	SD-22
EARTHQUAKE FAULT CROSSING MH CONNECTION.....	SD-23
2 FT. DIAMETER MH	SD-24

SECTION 1

INTRODUCTION

1.01 INTRODUCTION

It is the intent that these Standards apply to all sanitary sewer work, whether public or private, performed within the jurisdiction of the District unless said work is performed by the District under a separate contract and specifications.

The jurisdiction of the District includes the entire sewerage system and its appurtenances from the point of connection with the building drain to the discharge terminus of the treatment plant outfall.

Changes to these Standards may be made periodically and will be available to the public and contractors at the District offices and on the District website <http://www.oroloma.org>. Users of these Standards are urged to apprise themselves of all changes.

END OF SECTION 1

SECTION 2

DEFINITIONS AND ABBREVIATIONS

2.01 DEFINITIONS

Whenever in these Standards the following terms are used, the intent and meaning shall be interpreted as follows:

BEDDING AND SHADING - Bedding shall be defined as that material supporting the pipe. Shading shall be defined as the material surrounding and extending one foot above the top of the pipe.

BUILDING SEWER - A Building Sewer shall refer to any existing or proposed private sewer. It extends from the exterior connection of the building drain of the structure(s) to be served, to the point of connection, including the connection or wye fitting for which the District has permit authority and inspection jurisdiction, but no maintenance responsibility, to a collector sewer or main sewer, and it is subject to inspection and approval by the District, and when so approved, becomes the maintenance responsibility of the property owner. The connection or wye fitting is part of the building sewer and the District has no maintenance responsibility for the building sewer.

COLLECTOR SEWER - A Collector Sewer shall mean that private sanitary sewer, including the connection or wye fitting for which the District has permit authority and inspection jurisdiction, but no maintenance responsibility, which collects sewage from more than one building sewer on the same parcel and extends to the public sewer. The connection or wye fitting is part of the collector sewer and the District has no maintenance responsibility for the collector sewer.

CONTRACTOR - Company or individual authorized by the District to perform work by issuance of sewer permit.

DISTRICT - The Oro Loma Sanitary District of Alameda County, California.

DISTRICT BOARD - The governing body of the District.

ENGINEER - The Engineer appointed by the District acting either directly or through properly authorized agents, such agents acting within the scope of the particular duties delegated to them.

MAIN SEWER - A Main Sewer shall refer to any existing or proposed sewer dedicated to public use. It is subject to inspection and approval by the District and, when accepted, becomes the maintenance responsibility of the District.

PRIVATE SEWER - Private Sewer shall mean building sewer or collector sewer that is the property and maintenance responsibility of the property owner.

PUBLIC SEWER - Public Sewer shall mean a sewer lying within a street or easement and which is controlled by or under the jurisdiction of the District.

STANDARDS - The directions, provisions, requirements and detail drawings contained herein.

STANDARD DETAILS - Detailed standard drawings of approved construction in the District contained herein.

TRUNK SEWER - A main sewer 18-inch or more in interior diameter.

2.02 ABBREVIATIONS

ABS - Acrylonitrile Butadiene Styrene

AC - Asphalt Concrete

ANSI - American National Standards Institute

ASTM - American Society of Testing Materials

AWWA - American Water Works association

CIP - Cast Iron Pipe

DIP - Ductile Iron Pipe

HDPE - High Density Polyethylene

MH - Maintenance Hole

PVC - Polyvinyl Chloride

UPC - Uniform Plumbing Code

VCP - Vitrified Clay Pipe

END OF SECTION 2

SECTION 3

SEWER PIPE LINE

3.01 GENERAL

All sewer construction materials proposed to be used must be new first quality and approved for use by the District prior to start of construction. Whenever requested by the District, the Permit holder shall submit properly authenticated documents or other satisfactory proof of compliance with these standards.

3.02 PIPE MATERIAL

A. CLAY PIPE - Clay Pipe shall be Vitrified Clay (VCP) pipe and fittings, extra strength, bell and spigot or plain end pipe. The pipe and fittings shall conform in all respects to the most recent ASTM designations.

1. Joints - Bell and spigot joints shall be constructed with factory fabricated compression type gasket joints in accordance with ASTM C425 "Standard Specification for Compression Joints for Vitrified Clay Pipe and Fittings." Joints shall be made up in the field in accordance with the manufacturer's recommendations. All joints shall be tight fitting, watertight, and without imperfections. Only factory recommended lubricants shall be used.

Joints connecting pipes to MH structures shall be made with a short stub. The straight segment of stub barrel may not exceed 6-inch maximum from face of the structure.

Joints for VCP plain-end pipe sewers shall be Mission Flex-Seal ARC couplings or equal. All couplings shall include 316 stainless steel shields or shear bands held in place with 316 stainless steel worm drive clamps.

B. ABS PIPE - Acrylonitrile Butadiene Styrene (ABS) pipe and fittings shall be solid wall pipe and conform in all respects to the most recent ASTM designations. ABS pipe shall not be used for Public Sewers.

1. Pipe Wall Thickness - Private Sewer SDR 35
2. Joints - Joints for ABS pipe shall be solvent cement, solvent weld, or elastomeric gasket bell and spigot.

C. PVC - Polyvinyl Chloride (PVC) pipe and fittings shall be solid wall pipe conform in all respects to the most recent ASTM designations.

1. Pipe Wall Thickness - Private Sewer (non-paved) SDR 35
(paved) SDR 26
Public Sewer SDR 26

2. Joints - Joints for PVC pipe shall be solvent cement, solvent weld, or elastomeric gasket bell and spigot.
- D. HDPE - High Density Polyethylene (HDPE) pipe shall be solid wall and shall meet the requirements as described in ASTM D1248, D2657, D3035, D3261, D3350 and F714. The pipe shall contain no recycled compound except that generated in the manufacturer's own plant from resin of the same specification from the same raw material pipe.
1. Pipe Wall Thickness -

Private Sewer	SDR 17
Public Sewer	SDR 17
 2. Joints - Joints for HDPE Pipe installed through trenchless methods shall be butt-fusion welded, other installation methods may use electrofusion. All joints shall use materials and procedures as recommended by the pipe manufacturer. When the pipe is butt-fused the inside bead shall be removed after the pipe is fused. All HDPE to HDPE joints shall be fused.
 3. Color - Inner wall shall be white, light green, light red, or natural. Black, yellow, and light purple are not acceptable. The outside has the same color requirements but does not have to match the color of the inside wall.
- E. IRON PIPE - Cast Iron (CI) and Ductile Iron (DI) pipe shall not be used for public sewer without consent of the District Engineer. CI pipe for private sewers shall be soil pipe service weight, Class SV, or extra heavy, Class XH. DI pipe for private sewers shall be thickness Class 51 for 4-inch pipe and Class 50 for larger pipe.
1. Joints - Joints for Iron Pipe shall be standard integral mechanical joint of the same manufacture as the pipe, Smith-Blair or Dresser type couplings, sleeve type coupling, compression coupling consisting of a rubber coupler which is connected to the pipe with stainless steel compression bands, Tyton type joints, or approved equal, all installed as recommended by the manufacturer. All couplings shall have a shear band.
- F. Other Materials - Other pipe materials, joint couplings and pipe fittings may be used provided written approval of the District has been granted prior to installation. The District will require documentation that the pipe material being used is suitable for the conditions expected to be encountered in the proposed installation.

END OF SECTION 3

SECTION 4

MHs AND CASTINGS

4.01 MHs

All MHs shall be watertight structures with concentric cones and precast reinforced concrete barrel sections and shall have steps from top to bottom. MHs shall conform to the appropriate Standard Detail.

MHs shall have a forty-eight inch (48-inch) interior diameter for all sewers except that sixty inch (60-inch) interior diameter MHs are required for all sewers twenty-one inch (21-inch) or larger in diameter, and twenty-four inch (24-inch) diameter MHs may be used at the end of a terminal line with authorization from the Engineer.

A. CAST-IN-PLACE MH BASE BLOCK:

The base block shall be concrete and in accordance with the design shown on the Standard Details.

Cast-in-place concrete shall be placed only on dry, firm undisturbed ground or on 3/4-inch crushed rock placed on undisturbed ground, or as directed by the Engineer. If the pour is on filled ground, the ground shall be compacted to a 95% relative compaction. The concrete shall be placed with a continuous pour deposited in such a manner that segregation of material does not occur. Once deposited, it shall be consolidated so as to secure a dense watertight mass.

Internal vibrators will be required for consolidation of concrete on all poured MH base blocks. An approved metal form ring shall be on the job site so that a level keyed slot may be formed in the fresh concrete to receive the first precast section. (As an alternative to the form ring, the first precast section of the MH may be set plumb into fresh concrete.)

The width of opening at the top of base block shall be the inside diameter of the pipes in the MH.

In angle point MHs and in junction MHs, the pipes shall be joined by smooth curves, warped to conform with the lower half of the pipe. In all cases, the upper portion of the MH channel from the mid-point of the pipes in the MH to the top of the base block shall be constructed vertically.

When the MH channel is not completed in the original pour, it shall be finished smooth by use of non-shrink grout as specified by the Engineer. Before application of the non-shrink grout, the existing concrete surface shall be thoroughly cleaned and roughened to secure a firm bond. All channels shall be troweled smooth so that a smooth uninterrupted surface is achieved. The top of the base block shall be troweled to slope towards the channel at an approximate slope of one (1) inch in ten (10) inches.

B. MH BARREL AND PRECAST BASE BLOCK:

The MH barrel shall be composed of precast concrete sections. These sections shall be installed plumb and aligned so that the steps are in a straight vertical line. Unless otherwise required by the Engineer, the steps shall be aligned horizontally forty five (45) degrees away from the direction of the flow of the sewer main on the downstream side.

Precast concrete barrel sections shall be in accordance with the Standard Details and shall conform to the requirements of ASTM Designation C-478 except that Type II or Type V Portland Cement shall be used.

Unless otherwise directed by the Engineer, MHs will be constructed with concentric cone section per Standard Details. In these cases, the neck rings shall be installed after the street section has been completed.

Joints between precast sections shall have "Ram-Nek", or equal, flexible plastic gasket installed between the tongue and groove joint to make a watertight joint. After the shaft is in place, the joint shall be trimmed smooth with a sharp tool on the inside of the MH and the outside seam shall be grouted. After the grout has set wrap all joints with "RUB'R-NEK", or equal, joint wrap before backfilling.

C. MH STEPS:

Steps shall be installed in the MH cone and barrel sections by the MH manufacturer before being shipped to the job site unless the MH is specified by the Engineer to be without steps.

Steps for MHs shall be made of copolymer polypropylene that encapsulates a 1/2-inch grade 60 steel reinforcing rod. Steps shall have a non-slip tread surface and conform with ASTM Designation C-478, Paragraph 11.

D. MH CHANNEL:

1. Construction: The MH channel shall be formed from approved concrete and shall be troweled smooth, smooth enough to not stop any paper or debris.
 - The channel shall provide a smooth transition between varying pipe diameters.
 - The radius of the bottom of the channel shall match the inlet and outlet pipes.
 - Channel depth shall be 1-inch larger than the largest pipe diameter.
2. Channel slope through MH: The slope through the MH shall be designed to maintain a constant velocity through the system with a minimum flow of 2 ft/sec, while taking into account changing directions and materials. Slope shall be approved by the Engineer.

C. MH CONNECTIONS:

1. Water Stops: A water stop shall be installed on all plastic pipes entering or leaving a MH. Water stop shall be Christy's SBR (Styrene Butadiene

Rubber) or approved equal.

2. Lateral Connections: No residential (not including collector sewers on 10 or more units), small commercial, or small industrial laterals shall be connected to a MH, all laterals shall be routed downstream around the MH structure and connected to the District main via a wye.

4.02 CASTINGS

- A. Castings shall conform to the shape, weights and dimensions shown in the Standard Details.
- B. Castings shall be dipped or painted with an asphalt paint which will form a tough, tenacious, nonscaling coating which does not have a tendency to become brittle when cold or sticky when hot.
- C. MH frame and cover assemblies shall be machined so that the cover will seat evenly and firmly in the frame.
- D. In paved and unpaved areas, unless otherwise specified by the Engineer, a concrete collar shall be poured around the frame, adjusting ring, and cone as shown in the Standard Details.

END OF SECTION 4

SECTION 5

PORTLAND CEMENT CONCRETE AND GROUT

5.01 CONCRETE

Mix and deliver concrete in accordance with ASTM C94 utilizing the following mix design.

Unit	Measurement
Compressive Strength (28 day)	4,000 psi
Aggregate Size	3/4 inch (ASTM C33)
Slump	2 to 4 inches

- A. Portland cement used shall be Type II or Type V Sulfate Resistant Portland Cement (ASTM C150).
- B. Calcium chloride, not in excess of two (2) percent by volume, will be permitted when, in the Engineer's opinion, circumstances warrant its use.
- C. Water shall be clean and not detrimental to concrete. **Water from the sewer shall not be used.**

5.02 GROUT

In all grout mixtures, water shall be clean and not detrimental to grout. **Water from the sewer shall not be used.**

- A. Cement Grout: Grout shall consist of one (1) part Type I or Type II Portland Cement and two (2) parts sand. Sufficient water shall be added and thoroughly mixed to provide a plastic, workable and cohesive mixture and shall be further diluted with water to flow readily for grout. Grout shall meet the following:

Unit	Measurement
Compressive Strength (48 hours)	2,400 psi
Compressive Strength (28 days)	7,000 psi
Aggregate Size	Sand (ASTM C33)

- B. Non-Shrink Grout: Pre-mixed ready for use formulation requiring only addition of water (water from the sewer shall not be used); fast setting, non-shrink, non-corrosive, non-metallic, non-gas forming, no chlorides. In accordance with ASTM C1107. Non-Shrink Grout shall meet the following:

Unit	Measurement
Initial Set Time	15 minutes (approx.)
Final Set Time	35 minutes (approx.)
Compressive Strength (1 hour)	3,000 psi

Compressive Strength (3 hours)	5,000 psi
Compressive Strength (7 day)	7,000 psi
Compressive Strength (28 day)	9,000 psi
Shrinkage	None

END OF SECTION 5

SECTION 6

SEWER CONSTRUCTION AND REPAIR

6.01 GENERAL

Sewer pipe lines and appurtenances shall be constructed or repaired as shown on the Standard Details or ordered by the District Engineer and in accordance with these Standards.

6.02 SEWER PIPE LINES

- A. Public sewers shall have a minimum nominal size of eight (8) inches in diameter.
- B. Private sewers shall have a minimum nominal size in diameter as indicated below:
1. Building sewer for a single family residence: four (4) inches.
 2. Building sewer for a multiple family residence or nonresidential building: six (6) inches.
 3. Collector sewers accepting discharge from two or more building sewers: six (6) inches.
 4. Force mains in pumped systems: four (4) inches unless otherwise approved by the Engineer.
- C. Sewers shall be designed and constructed to the maximum slope possible consistent with good design practices but in no case less than the minimum listed below, measured in feet per foot (inch/foot) unless authorized by the Engineer:

<u>Nominal Pipe Size</u>	<u>Plastic Pipe min. slope</u>	<u>All Other Pipe min. slope</u>
4-inch	0.01 (1/8)	0.01 (1/8)
6-inch	0.004	0.005 (1/16)
8-inch	0.003	0.0035
10-inch	0.002	0.0025
12-inch	0.0017	0.0020
15-inch	0.0012	0.0015
18-inch	0.0010	0.0012
>18-inch	0.0010	0.0010

- D. Minimum depth of cover from top of pipe to finished grade for sewers is shown in the Standard Details.

- E. Sewers to be abandoned shall be securely closed at all pipe ends by an approved cap or at MH entries, by a watertight plug of concrete, or brick and grout, not less than two (2) feet thick.

Building sewer shall be abandoned at the point of connection to the public sewer. Where the connection or wye is damaged or protruding into the public sewer, the connection or wye shall be removed and the public sewer repaired with like material. Break in taps will require removal and repair of the public sewer. On HDPE mains the fused connection or wye shall be capped with an approved cap fused in place.

6.03 BACKWATER PREVENTION SYSTEM

A backwater prevention system (BPS) shall be installed at the outlet(s) of each structure at the time any repair is performed on any residential, commercial, or industrial private lateral or private collector sewer. The BPS shall be installed no further than 6-feet and no closer than 2-feet to the building line. Except as approved by the Engineer on collector sewer, the backwater check valve shall be installed immediately downstream of the two way clean-out. See SD-15.

6.04 SEWER INSTALLATION METHOD

Excavation for sewers shall be made by open trenching except where a trenchless method is acceptable to the District. Attention is directed to SD-16 for pipe trench details.

Prior to any excavation for sewer work in a public right-of-way the Permit holder shall have available at the job site evidence of permits for work in State or County roads and/or City streets. A CAL/OSHA permit is also required for all excavation work and must be provided upon request. Contractor shall solely be responsible for meeting all CAL/OSHA requirements, including but not limited to sheeting, shoring, and bracing, or equivalent method for the protection of life and limb in trenched and open excavations.

Where solid rock is encountered, it shall be removed to a minimum of four (4) inches below the outside bottom of the pipe and the trench backfilled with bedding material as specified in this section.

Where mud or other soft or spongy material incapable of proper pipe support is encountered, all such material shall be excavated and replaced as shown in SD-16.

The Permit holder shall furnish, install and operate all necessary pumps and appurtenant equipment to keep all trenches and other excavations reasonably free from water during construction and shall dispose of the water so as not to cause injury to public or private property or to create a nuisance or menace to the public.

1. Trenchless Sewer Replacement: Trenchless installation of private sewers shall not be acceptable in pipes with existing sags greater than 0.125 times the

- nominal diameter of the pipe or where the sewer connects to the public sewer below the spring line of the public sewer.
2. Private sewers shall not be replaced or repaired using methods that reduces the inside diameter of the pipe below the minimum nominal size.

6.05 BEDDING AND SHADING

Attention is directed to the Standard Details for applicable pipe bedding and shading details.

Sand and pea gravel bedding and shading shall not be used.

Granular bedding and shading, free of deleterious substances, shall be of the following gradations:

3/4-inch CRUSHED ROCK	
<u>Sieve Size</u>	<u>% Passing</u>
1-inch	100
3/4-inch	90-100
1/2-inch	30-60
3/8-inch	0-20
#4	0-5

6.06 BACKFILL AND COMPACTION

Backfill material shall be placed and consolidated in such a manner as to prevent damage to any sewer, roadbed, road surface, utility or private property.

Trench backfill shall be compacted to a minimum of 95% or to the requirements of the agency having jurisdiction and in such a manner as to prevent settlement.

6.07 UTILITIES AND STORM DRAINS

A. RELOCATIONS:

When new utility pipe/conduit or storm drain conflicts with the grade of an existing sewer line, the new facility shall be raised or lowered, if possible, to miss the sewer line. If this is not possible, the sewer line shall be relocated in accordance with these standards.

B. REPAIRS:

During the course of installation of new utility pipe/conduit or storm drain, repairs to damaged sewers shall be made with matching pipe in accordance with the Standard Details.

C. STORM DRAIN CROSSING:

When storm drain pipe/conduit passes under or over an existing sewer, or a new sewer line crosses under an existing storm drain pipe/conduit, it shall be necessary to install PVC pipe for the sewer at such crossings, in accordance with the Standard Details.

6.08 CONNECTIONS TO EXISTING SEWERS

It shall be the responsibility of the contractor to determine the exact location and depth of existing sewers prior to the laying of any sewer pipe. The contractor shall also determine the elevation of the building drain outlet to be connected and whether the required grade can be maintained between the outlet and the main sewer prior to construction of any portion of the building and/or collector sewer.

A. PRIVATE LATERAL AND COLLECTOR CONNECTIONS:

1. EXISTING MHS: No lateral connections shall be made to existing sewer main MHs. Collector sewer connections may be made to existing sewer main MHs only with the Engineer's approval.
2. NEW MHS: Where the District Engineer approves connection to an existing sewer by construction of a new MH, such construction shall conform to the Standard Details.
3. WYE: Connections to sewer mains shall be made by splicing a 45-degree wye of the same material into the existing main. Connection between new and existing pipe shall be made with stainless steel mechanical type compression coupling with an external shear band or as directed by the Engineer. The wye shall be installed so that the lateral connection is above the spring line of the pipe.

Tees are not allowed for use in sewer connections or fittings.

The trench from the connection shall extend under the main and the soil under the main shall be removed and replaced per SD-16 to provide a firm base for the new connection.

4. TAPS: The use of taps employing core drilling techniques and specially designed fittings for connection to sewer mains is not acceptable.

B. PUBLIC SEWER CONNECTIONS: There shall be no public connections to existing sewers utilizing splices or taps.

1. EXISTING MHS: Connections to existing MHs will require rebuilding the MH to meet the standard details. Penetrations into existing MHs shall be done by coring.
2. NEW MHS: Where the District Engineer approves connection to an existing sewer by construction of a new MH, such construction shall conform to the Standard Details.

6.09 REPAIRS TO EXISTING SEWERS

It shall be the responsibility of the contractor to verify the location and depth of the repair before excavating.

It shall be the responsibility of the contractor, at their expense, to possess or obtain all necessary permits and licenses prior to commencing work. Copies of permits shall be submitted to the Engineer. The contractor will observe all applicable safety and health regulation in prosecuting the work. All repair work shall receive an inspection by the Engineer prior to covering the repaired pipe. The final inspection will take place via CCTV after the pipe is loaded with the trench backfill.

A. SEWAGE FLOW:

The contractor shall contain within or bypass to the sanitary sewer system all sewage flow in a manner to limit contamination of the surrounding area and maintain a stable foundation for repair pipe bedding.

1. All flow control or diversion systems shall be submitted to the Engineer for review and approval.
2. All flow control or diversion systems shall be sized with sufficient capacity to accommodate the maximum dry weather flow and to provide additional capacity for unexpected events or rainstorms.
3. If pumped bypass systems are used, Contractor shall provide emergency standby pump(s) capable of maintaining the bypass.

B. GROUNDWATER:

The contractor shall control groundwater encountered in the excavation to maintain a stable foundation for installing pipe bedding.

C. UNSUITABLE MATERIAL:

The contractor shall remove from the excavation all material deemed unsuitable by the District and replace it with 3/4-inch crushed rock wrapped in filter fabric, to a minimum 12-inch depth, to provide a stable foundation for pipe bedding.

D. PIPE MATERIAL:

Repairs to public sewers shall be made with the same pipe material as the existing damaged pipe, subject to the requirements of Section 3.02. In circumstances where the District determines that extra strength is required, PVC solid wall pipe (AWWA C900) DR 14 shall be used.

Repairs to private sewers shall be made with the same pipe material as the existing damaged pipe, subject to the requirements of Section 3.02.

Sewers which are repaired trenchlessly, only a portion of the sewer is replaced, shall be connected back with HDPE or the existing pipe material; no additional pipe materials shall be used.

E. PIPE JOINTS:

The contractor shall make repairs in a manner to minimize the number of joints and shall use a stainless steel banded rubber compression type coupling with stainless steel shear band, with bushings as required, for all repair joints for public sewers and any joint method approved by the Engineer for private sewers. Couplings shall be Mission Rubber Company Flex-Seal ARC Shielded Adjustable sewer Repair Couplings or approved equal.

F. BEDDING:

The contractor shall place all repair pipe on a bedding of 3/4-inch Crushed Rock to a minimum depth of 6-inches.

G. SHADING:

The contractor shall place 3/4-inch Crushed Rock around and over the pipe to a minimum of 12-inch over the top of pipe, shovel spading the haunch area during placement. All repair work shall receive inspection by the Engineer prior to shading the repair pipe.

H. TRENCH BACKFILL AND COMPACTION:

The contractor shall meet the requirements of the public agency having jurisdiction for trench backfill and compaction.

After trench backfill and compaction the sewer repair will be inspected by the District via CCTV. Pipe diameters shall match, and there shall be no offset joints nor shall the combined gap between the two ends exceed 1/2 of an inch, as determined by the Engineer. The District shall have 48 hours to perform this inspection not including holidays or weekends. The Contractor may pave, at their own risk, before this inspection takes place.

I. PAVEMENT REPLACEMENT:

The contractor shall meet the requirements of the public agency having jurisdiction for pavement replacement.

END OF SECTION 6

SECTION 7

TESTING

7.01 GENERAL

All acceptance and approval tests shall be done in the presence of the Engineer.

Any portion of the sewer found not to be in conformance with these Standards must be corrected by the Contractor. Sewers so corrected shall be re-tested and inspected in accordance with the requirements of these Standards and at the sole expense of the Contractor.

The District may, at its discretion, charge for additional inspections when re-testing is required.

7.02 TESTS FOR OBSTRUCTIONS

The testing of all plastic sewer lines include testing by mandrel (95%). The contractor shall provide necessary labor and equipment for the test at their sole expense.

7.03 TESTS FOR LEAKAGE

Leakage tests for final acceptance or approval of the sewers and MHs shall be performed after all compaction work is complete, after all other utilities are in place, and grading work is complete. In paved areas this test will normally be performed immediately after final compaction and prior to placement of paving material. The program of testing must fit the conditions as mutually determined by the Engineer and the contractor. The contractor shall furnish all labor, tools, plugs and equipment necessary to make the tests and to perform any work incidental thereto at his sole expense. The contractor shall take all necessary precautions to prevent any damage or dislocation of any kind while the pipelines or their appurtenances are being tested. The contract shall, at their own expense, correct any leakage and repair any damage to the pipeline and its appurtenances or to any structures resulting from or caused by these tests.

A. SEWER LINES

- 1 Air Test: The Contractor shall plug and brace the ends of the sewer lines being tested and furnish air, from a compressor with adequate capacity to maintain four (4) pounds per square inch gage (psig) pressure in the line under test, through gauging and testing equipment furnished and operated by the contractor. After an internal pressure of 4.0 psig has been maintained for approximately two minutes, the supply of air shall be disconnected and the District will then accurately determine the time for loss of one (1) psig, from three and one-half (3½) to two and one-half (2½) psig. The minimum acceptable time for loss of one (1) psig shall be determined by using the following table:

<u>SIZE OF PIPE</u>	<u>LENGTH OF LINE (feet)</u>	<u>LENGTH OF TEST (minutes)</u>
4-inch	ALL	4
6-inch	ALL	4
8-inch	ALL	4
10-inch	ALL	5
12 to 14-inch	ALL	5
15 to 18-inch	0 - 120	6
15 to 18-inch	120-165	7
15 to 18-inch	GREATER THAN 165	8

When a combination of more than one pipe size is under test, the maximum test time for the larger pipe shall apply.

If the time for the loss of one (1) psig is less than computed by using the above schedule, the contractor shall make such repairs as are necessary to the satisfaction of the Engineer to eliminate the excessive leakage. The repaired section of pipe shall then be retested and subjected to all other approval tests and cleaning requirements.

2. Water Test: Contractors may on 4-inch lateral sewers utilize a water test. The contractor shall plug the lowest downstream point and plug the connection to the structure(s), install a 9-foot riser measured from the highest point on the repaired lateral sewer. Once the riser is filled with water, the level cannot drop over a 4-minute period. If the water level drops the contractor shall drain and repair the deficiency and then re-test.

B. MHS

Test using air whenever possible prior to backfilling to assist in locating leaks. Make joint repairs on both outside and inside of joint to ensure permanent seal. Test MHs with MH frame set in place. When unsatisfactory test results are achieved, repair MH and retest until result meets criteria; repair visible leaks regardless of quantity of leakage.

Vacuum test in accordance with ASTM C1244 and as follows: Plug pipe openings; securely brace plugs and pipe; Inflation compression band to effect seal between vacuum base and structure; connect vacuum pump to outlet port with valve open; draw vacuum to 10 inches of Hg; close valve; start test.

Test:

1. Determine test duration for MH from the following table:

<u>VACUUM TEST TABLE</u>	
<u>MH Diameter</u>	<u>Test Period</u>
4 feet	60 seconds
5 feet	75 seconds
6 feet	90 seconds

2. Record vacuum drop during test period; when vacuum drop is greater than 1 inch of Hg during test period, repair and retest MH; when vacuum drop of 1 inch of Hg does not occur during test period, discontinue test and accept MH.
3. When vacuum test fails to meet 1 inch Hg drop in specified time after repair, repair and retest MH.

END OF SECTION 7

SECTION 8

CLEANING

8.01 GENERAL

After the sewers have satisfactorily passed the tests required in Section 7 and all structures are complete, the Contractor, in the presence of the Engineer, shall clean each section of the sewer. Contractor will be responsible for the clean up to the property Owner's and District's satisfaction in the event that the cleaning causes any discharge or backup of water or sewage into a building, residence, or onto the ground; all costs shall be the Contractor's exclusively. Contractor shall clean the sewer in the following manner:

- A. **SEWERS SIX (6) INCHES THROUGH TWELVE (12) INCHES IN DIAMETER:**
Cleaning shall be completed with the use of hydraulically propelled, high-velocity jet (hydrocleaning) equipment. The equipment shall have a selection of four or more high-velocity nozzles. The nozzles shall be capable of producing a scouring action from 15 to 45 degrees in all size lines designated to be cleaned. The range of water pressure shall be both sufficient enough to completely clean the sewer, yet gentle enough not to displace or damage the sewer.

As the debris is pulled to the MH with the hydro it shall be removed and not allowed to flush downstream.

- B. **SEWERS FIFTEEN (15) INCHES IN DIAMETER AND LARGER:**
The Engineer shall visually inspect the sewer and if in his opinion cleaning is necessary, the Contractor shall clean the sewer to the satisfaction of the Engineer utilizing the methods required by the Engineer. District may clean the sewer in these sizes at the Contractor's request and at their expense.
- C. **FOUR (4) INCH AND SIX (6) INCH BUILDING SEWERS:**
When in the opinion of the Engineer, the sewer is not clean it shall be flushed or otherwise cleaned so as to properly serve its intended function. If debris is flushed into the District main, the District main shall be cleaned to the next downstream MH and the debris removed.

END OF SECTION 8

SECTION 9

TELEVISION INSPECTION (PUBLIC SEWERS)

8.01 GENERAL

The Contractor shall provide CCTV inspection of main sewers, at their expense.

8.02 EXECUTION

Television inspection shall be conducted only after final air testing in conformance with Section 7, and after cleaning in conformance with Section 8.

Any portion of the sewer found not in conformance with these Standards must be corrected by the Contractor. Sewers so corrected shall be re-tested and inspected in accordance with the requirements of these Standards at no additional cost to the District. The District may, at its discretion, charge for additional inspections when re-testing is required.

1. Utilize cameras specifically designed and constructed for closed-circuit sewer line inspection. Utilize camera equipment with pan and tilt capability to view each lateral connection at multiple angles.
2. Utilize camera capable of moving both upstream and downstream; minimum 1,000 feet horizontal distance with one setup; direct reading cable position meter.
3. Inspection shall be recorded upon a clean new USB flash drive in a format able to be read on a standard computer without installing any software and submitted to the Engineer. The District may not return the USB flash drive.

END OF SECTION 9

SECTION 10

SITE CLEANUP AND RESTORATION (PUBLIC SEWERS)

10.01 GENERAL

- A. Surplus pipeline material, tools, remaining material from site preparation, etc., shall be removed by the Contractor, and all dirt, broken pavement, rubbish and excess earth from excavation shall be hauled to a legal and approved dump site by the Contractor and the construction site left clean, to the satisfaction of the Engineer. Disposal tags shall be provided to the Engineer upon request.
- B. Replaceable items such as fences, signs, landscaping, etc., requiring removal during construction operations must be replaced in kind by the Contractor at their expense. Any driveway areas or other improvements requiring removal and/or excavation will be restored to a condition equivalent to their original condition all to the satisfaction of the Engineer. The Contractor shall obtain a release from property owners at the end of the project, a copy of the release shall be provided to the Engineer upon request.
- C. On District contract projects and repairs, the value of and responsibility for damage to objects that cannot be replaced in kind must be negotiated between the Contractor and the Engineer prior to the removal of those objects.

END OF SECTION 10

SECTION 11

STANDARD DETAILS

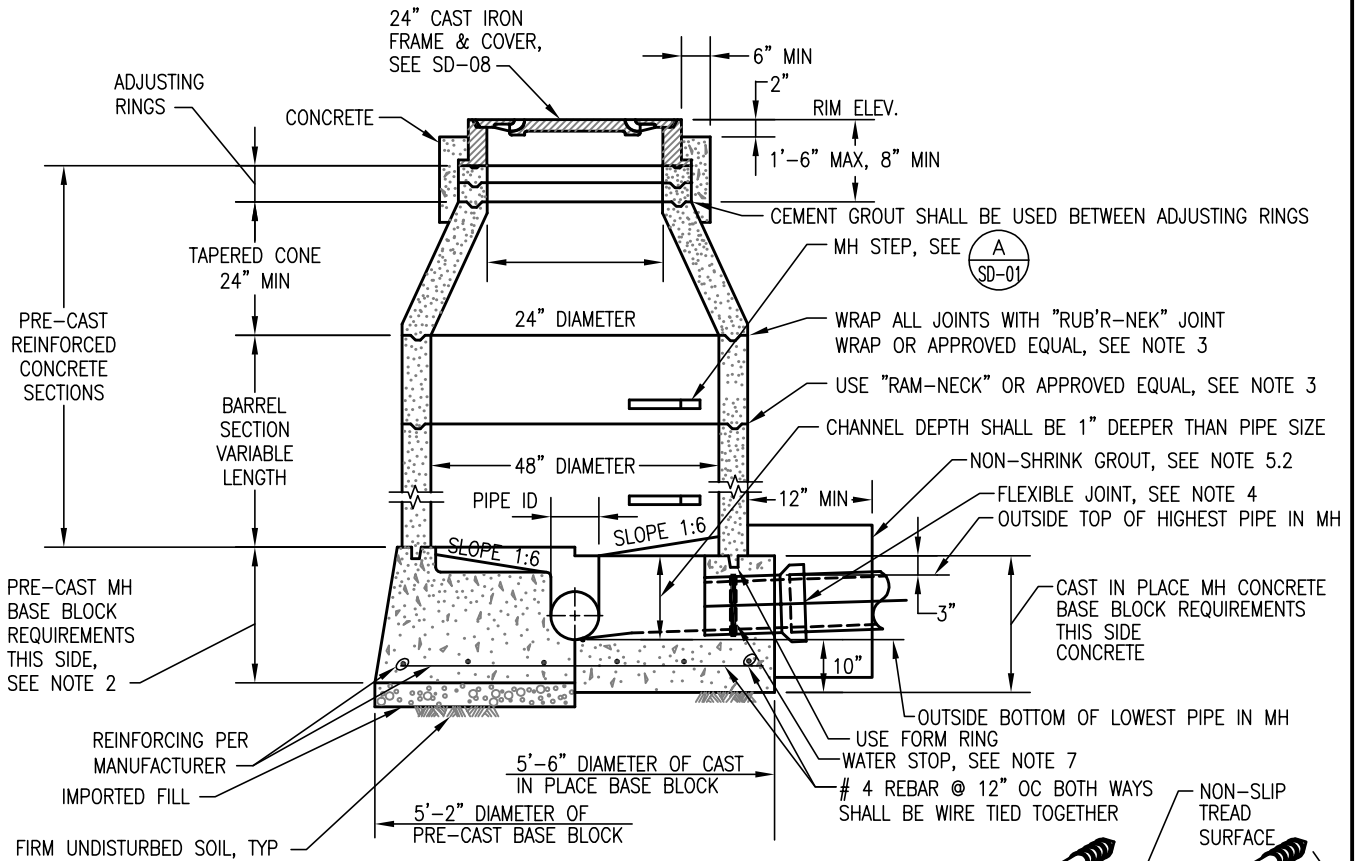

NOTES:

1. ALL PRE-CAST UNITS SHALL BE MANUFACTURED AND TESTED IN ACCORDANCE WITH ASTM C478.
2. PRE-CAST MH BASE BLOCKS SHALL ONLY BE USED AFTER PRIOR APPROVAL HAS BEEN RECEIVED FROM THE DISTRICT ENGINEER FOR EACH LOCATION TO BE USED.
3. INSTALL "RAM-NECK" BETWEEN EACH JOINT OF THE CONE AND BARREL SECTIONS TO MAKE A FLEXIBLE WATER TIGHT JOINT. AFTER JOINT IS MADE, TRIM EXCESS RAM-NECK THEN GROUT JOINTS ON THE INSIDE AND OUTSIDE OF MH. AFTER GROUT HAS SET WRAP ALL OUTSIDE JOINTS WITH "RUB'R-NEK JOINT WRAP OR APPROVED EQUAL.
4. A FLEXIBLE JOINT IS REQUIRED ON 6", 8", 10", & 12" DIAMETER NON-PLASTIC PIPE. THE FLEXIBLE JOINT SHALL BE INSTALLED AS CLOSE AS POSSIBLE TO MH BASE BLOCK (6" MIN., 12" MAX.) TO PROVIDE PIPE FLEXIBILITY.
5. ON PLASTIC PIPES ENTERING OR LEAVING MH BASES:
 - 5.1. AN APPROVED WATER STOP SHALL BE INSTALLED. THE WATER STOP SHALL BE CENTERED UNDER THE MH WALL OR AS SHOWN.
 - 5.2. NON-SHRINK GROUT BLOCK SHALL BE PLACED AROUND PLASTIC PIPE AT THE MH BASE PENETRATION. BLOCK SHALL BE 12" IN LENGTH AND 12" THICKER THAN THE OUTSIDE DIAMETER OF THE PIPE, CENTERED ON THE PIPE.
6. PRE-CAST SECTIONS SHALL BE INSTALLED SO THAT THE STEPS ARE ALIGNED VERTICALLY AND AS SHOWN IN THE PLAN SECTION.

ELEVATION SECTION

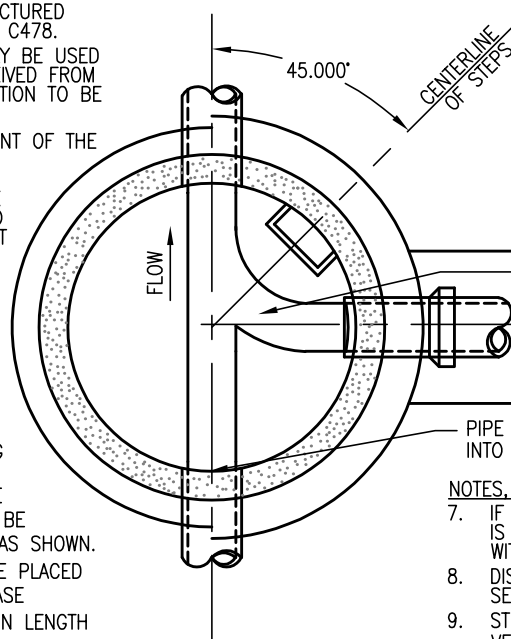

PLAN SECTION

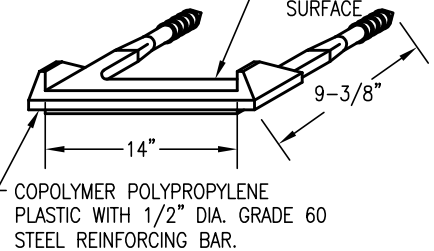

(A) MH STEPS
SD-01 NO SCALE

SIDE SEWER FLOW SHALL BE CHANNELIZED IN AT A 45° ANGLE OR AS DIRECTED BY THE DISTRICT ENGINEER.

PIPE TO BE INSTALLED FLUSH WITH BASE. PROTRUSION INTO MH NOT TO EXCEED 1".

NOTES, CONT'D:

7. IF DISTANCE FROM MH RIM TO TOP OF BASE BLOCK IS LESS THAN 4 FEET ORDER PRE-CAST SECTIONS WITHOUT STEPS.
8. DISTANCE FROM MH RIM TO FIRST STEP IN PRECAST SECTION SHALL BE NO GREATER THAN 24 INCHES.
9. STEPS SHALL BE EVENLY SPACED. MAXIMUM VERTICAL SPACING OF STEPS SHALL BE 16", WITH THE BOTTOM STEP A MAXIMUM OF 2" ABOVE THE SHELF.
10. MHS PLACED IN LANDSCAPED AREAS SHALL HAVE 4" THICK 6' BY 6' CONCRETE PAD PLACED AROUND THE RISER. THE PAD SHALL BE INSTALLED PER ORO LOMA SD-19.

DATE SEPT 2023 SHEET SD-01
 DRAWN WDH
 APPROVED [Signature]
 DISTRICT ENGINEER, RCE #68475



ORO LOMA SANITARY DISTRICT
 2600 GRANT AVENUE, SAN LORENZO, CA 94580

MAIN MH

DATE MARCH 2023 SHEET SD-02
DRAWN _____
APPROVED _____
DISTRICT ENGINEER, RCE #68475



ORO LOMA SANITARY DISTRICT
2600 GRANT AVENUE, SAN LORENZO, CA 94580

NOT USED

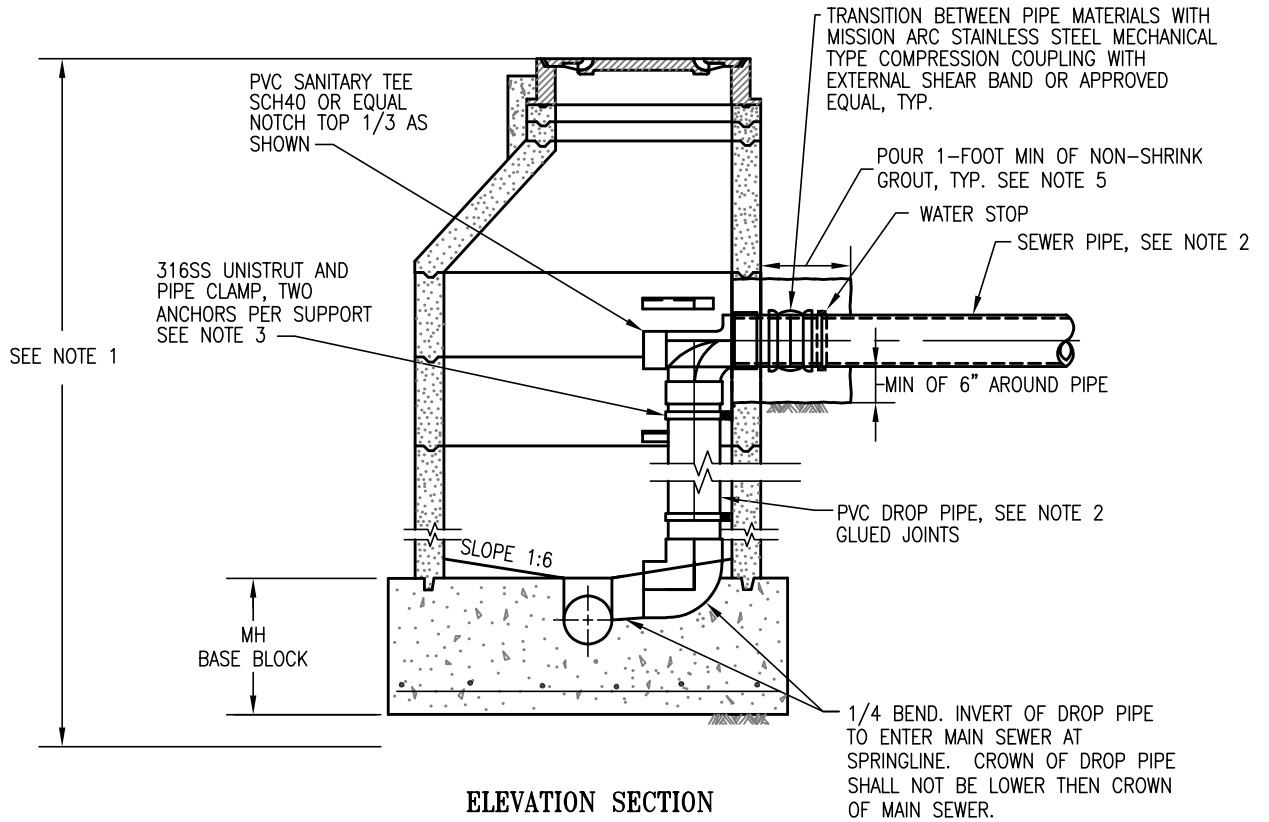

SIDE SEWER FLOW SHALL BE CHANNELIZED IN AT A 45° ANGLE OR AS DIRECTED BY ENGINEER.

NOTES:

1. EXCEPT AS INDICATED HEREON OR ON THE PROJECT PLANS, MHs SHALL CONFORM TO STANDARD DETAIL SHEET SD-01: MAIN MH.
2. DROP TEE AND PIPE SHALL BE THE SAME SIZE AS THE SEWER PIPE.
3. UNLESS OTHERWISE NOTED, ALL ANCHORS SHALL BE SIMPSON-XP EPOXY 2-1/2" EMBED WITH 3/8" 316SS ATR, NUT AND WASHER. MAXIMUM DISTANCE BETWEEN DROP PIPE SUPPORTS SHALL BE 24" WITH A MINIMUM OF TWO SUPPORTS PER INSTALLATION.
4. DROP TEE ONLY ALLOWED IN THE STRAIGHT WALLED PORTION OF ECCENTRIC MH.
5. CONTRACTOR SHALL OPEN CUT SECTION OF THE PIPE PENETRATION ON THE OUTSIDE OF THE MH TO FORM, POUR AND VIBRATE GROUT. FORMWORK TO BE REMOVED BEFORE BACKFILL.

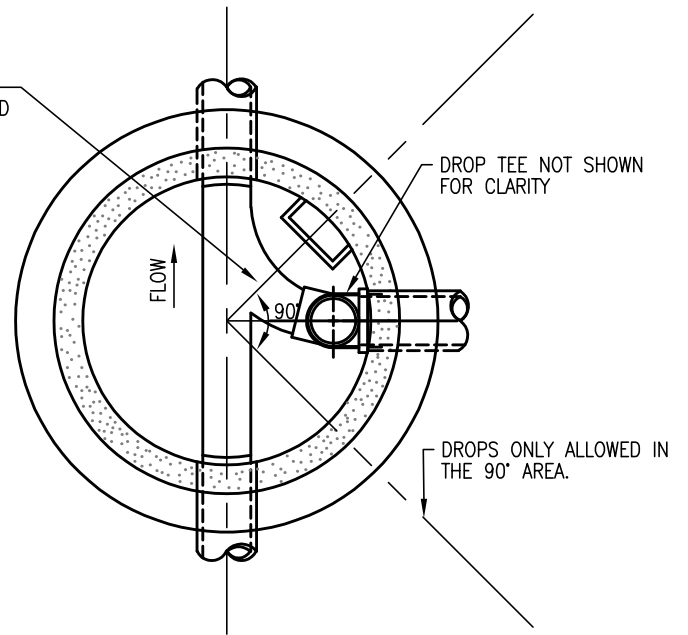

DATE SEPT 2023 SHEET SD-03
 DRAWN KMD
 APPROVED [Signature]
 DISTRICT ENGINEER, RCE #68475



ORO LOMA SANITARY DISTRICT
 2600 GRANT AVENUE, SAN LORENZO, CA 94580

INSIDE DROP
 MAIN MH

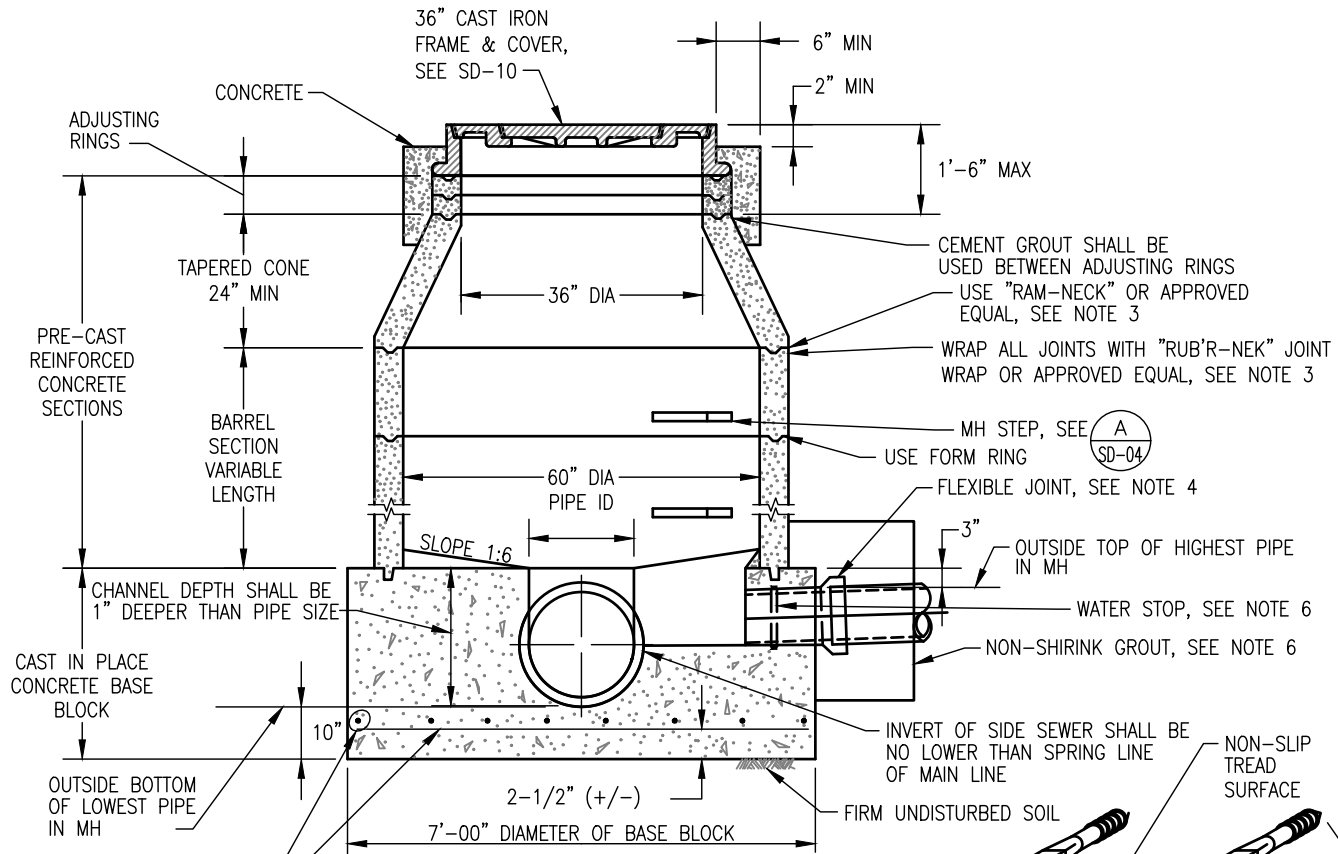

ELEVATION SECTION

#4 REBAR @ 12" O.C. BOTH WAYS, REBAR IS TO BE WIRE-TIED TOGETHER.

NOTES:

1. ALL PRE-CAST UNITS SHALL BE MANUFACTURED & TESTED IN ACCORDANCE WITH ASTM C478.
2. TRUNK MHS ARE REQUIRED WHEN THE SEWER LINE IS 21" OR LARGER IN DIAMETER.
3. INSTALL "RAM-NECK" BETWEEN EACH JOINT OF THE CONE AND BARREL SECTIONS TO MAKE A FLEXIBLE WATER TIGHT JOINT. AFTER JOINT IS MADE, TRIM EXCESS RAM-NECK THEN GROUT JOINTS ON THE INSIDE AND OUTSIDE OF MH. AFTER GROUT HAS SET WRAP ALL OUTSIDE JOINTS WITH "RUB'R-NEK" JOINT WRAP OR APPROVED EQUAL.
4. THE FLEXIBLE JOINT SHALL BE INSTALLED AS CLOSE AS POSSIBLE TO MH BASE BLOCK (6" MIN., 12" MAX.) TO PROVIDE PIPE FLEXIBILITY.
5. PRE-CAST SECTIONS SHALL BE INSTALLED SO THAT STEPS ARE ALIGNED VERTICALLY AND AS SHOWN IN THE PLAN SECTION.
6. ON PLASTIC PIPES ENTERING OR LEAVING MH BASES:
 - 6.1. AN APPROVED WATER STOP SHALL BE INSTALLED. THE WATER STOP SHALL BE CENTERED UNDER THE MH WALL OR AS SHOWN.
 - 6.2. NON-SHRINK GROUT BLOCK SHALL BE PLACED AROUND PLASTIC PIPE AT THE MH BASE PENETRATION. BLOCK SHALL BE 12" IN LENGTH AND 12" THICKER THAN THE OUTSIDE DIAMETER OF THE PIPE, CENTERED ON THE PIPE.

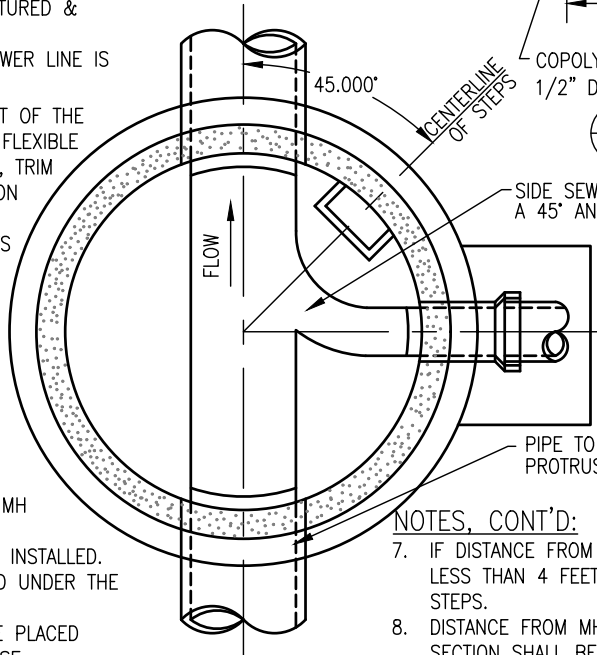

PLAN SECTION

NOTES, CONT'D:

7. IF DISTANCE FROM MH RIM TO TOP OF BASE BLOCK IS LESS THAN 4 FEET ORDER PRECAST SECTIONS WITHOUT STEPS.
8. DISTANCE FROM MH RIM TO FIRST STEP IN PRECAST SECTION SHALL BE NO GREATER THAN 24 INCHES.
9. STEPS SHALL BE EVENLY SPACED. MAXIMUM VERTICAL SPACING OF STEPS SHALL BE 16", WITH THE BOTTOM STEP A MAXIMUM OF 2 FEET ABOVE THE SHELF.

DATE MARCH 2023 SHEET SD-04
 DRAWN JTD
 APPROVED [Signature]
 DISTRICT ENGINEER, RCE #68475



ORO LOMA SANITARY DISTRICT
 2600 GRANT AVENUE, SAN LORENZO, CA 94580

TRUNK MH

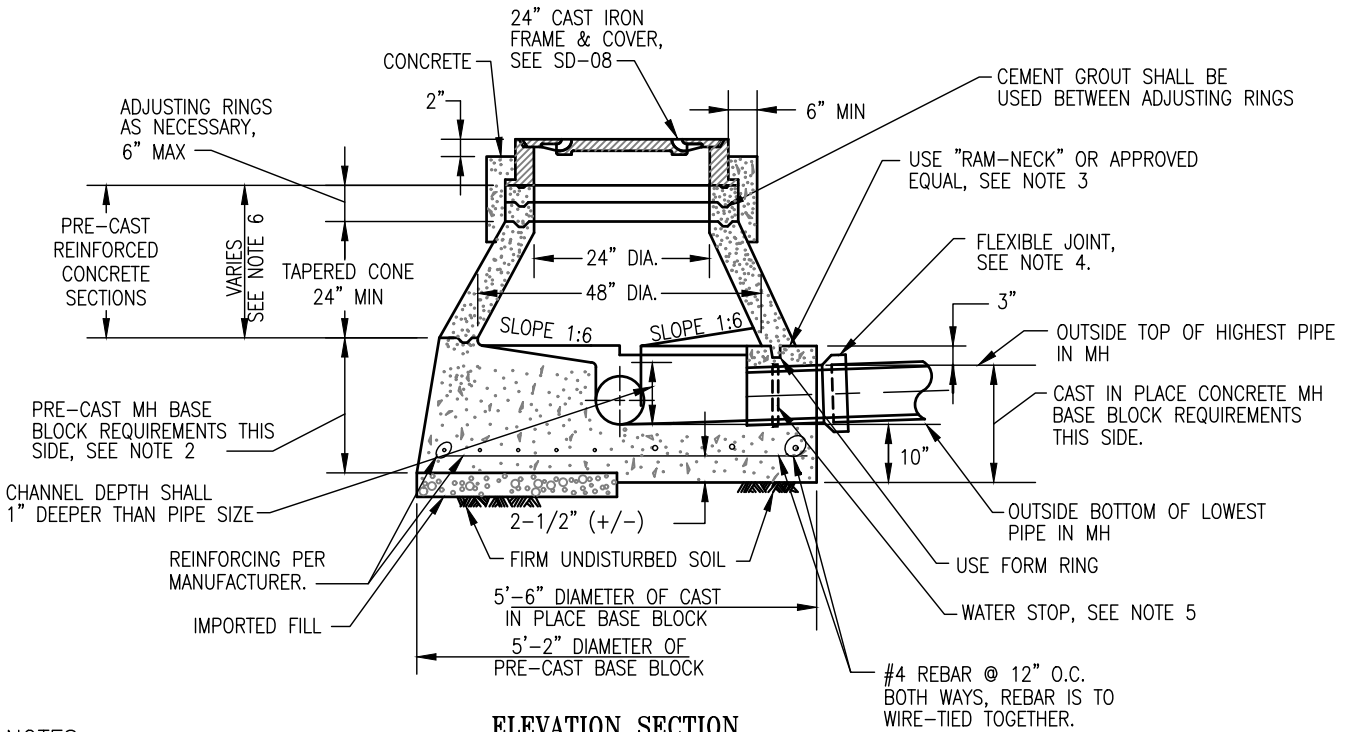

ELEVATION SECTION

NOTES:

1. ALL PRE-CAST UNITS SHALL BE MANUFACTURED AND TESTED IN ACCORDANCE WITH ASTM C478.
2. PRE-CAST MH BASE BLOCKS SHALL ONLY BE USED AFTER PRIOR APPROVAL HAS BEEN RECEIVED FROM THE DISTRICT ENGINEER FOR EACH LOCATION TO BE USED.
3. INSTALL "RAM-NECK" BETWEEN EACH JOINT OF THE CONE AND BARREL SECTIONS TO MAKE A FLEXIBLE WATER TIGHT JOINT. AFTER JOINT IS MADE, TRIM EXCESS RAM-NECK THEN GROUT JOINTS ON THE INSIDE AND OUTSIDE OF MH. AFTER GROUT HAS SET WRAP ALL OUTSIDE JOINTS WITH "RUB'R-NEK JOINT WRAP OR APPROVED EQUAL.
4. A FLEXIBLE JOINT IS REQUIRED ON 6", 8", 10", & 12" DIAMETER NON-PLASTIC PIPES. THE FLEXIBLE JOINT SHALL BE INSTALLED AS CLOSE AS POSSIBLE TO MH BASE BLOCK (6" MIN., 12" MAX.) TO PROVIDE PIPE FLEXIBILITY.
5. ON PLASTIC PIPES ENTERING OR LEAVING MH BASES:
 - 5.1. AN APPROVED WATER STOP SHALL BE INSTALLED. THE WATER STOP SHALL BE CENTERED UNDER THE MH WALL OR AS SHOWN.
 - 5.2. NON-SHRINK GROUT BLOCK SHALL BE PLACED AROUND PLASTIC PIPE AT THE MH BASE PENETRATION. BLOCK SHALL BE 12" IN LENGTH AND 12" THICKER THAN THE OUTSIDE DIAMETER OF THE PIPE, CENTERED ON THE PIPE.
6. SHALLOW MAIN MH MAY BE USED WHERE DISTANCE FROM TOP OF BASE TO BOTTOM OF FRAME IS BETWEEN 24" AND 30".

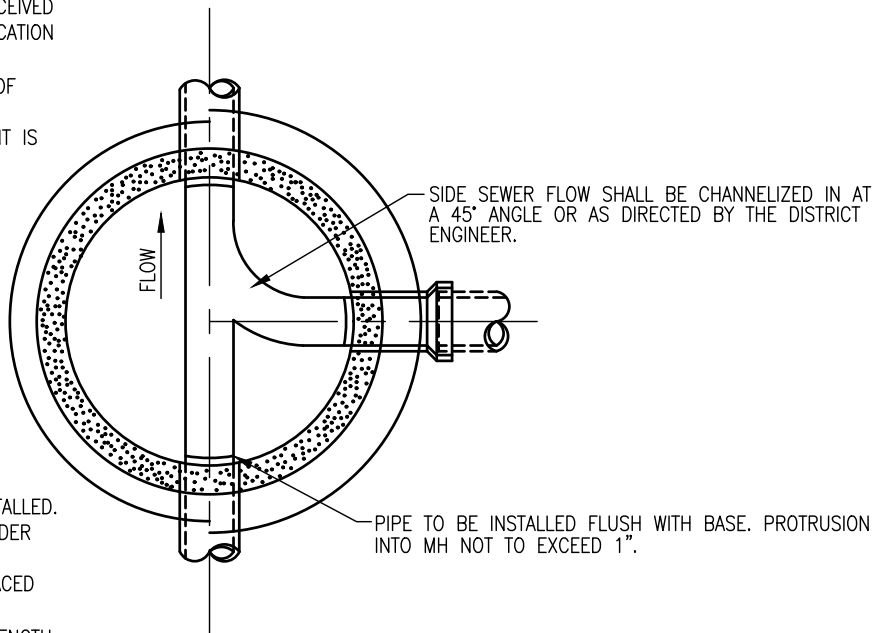

PLAN SECTION

DATE MARCH 2023 SHEET SD-05
 DRAWN JTD
 APPROVED [Signature]
 DISTRICT ENGINEER, RCE #68475



ORO LOMA SANITARY DISTRICT
 2600 GRANT AVENUE, SAN LORENZO, CA 94580

SHALLOW
 MAIN MH

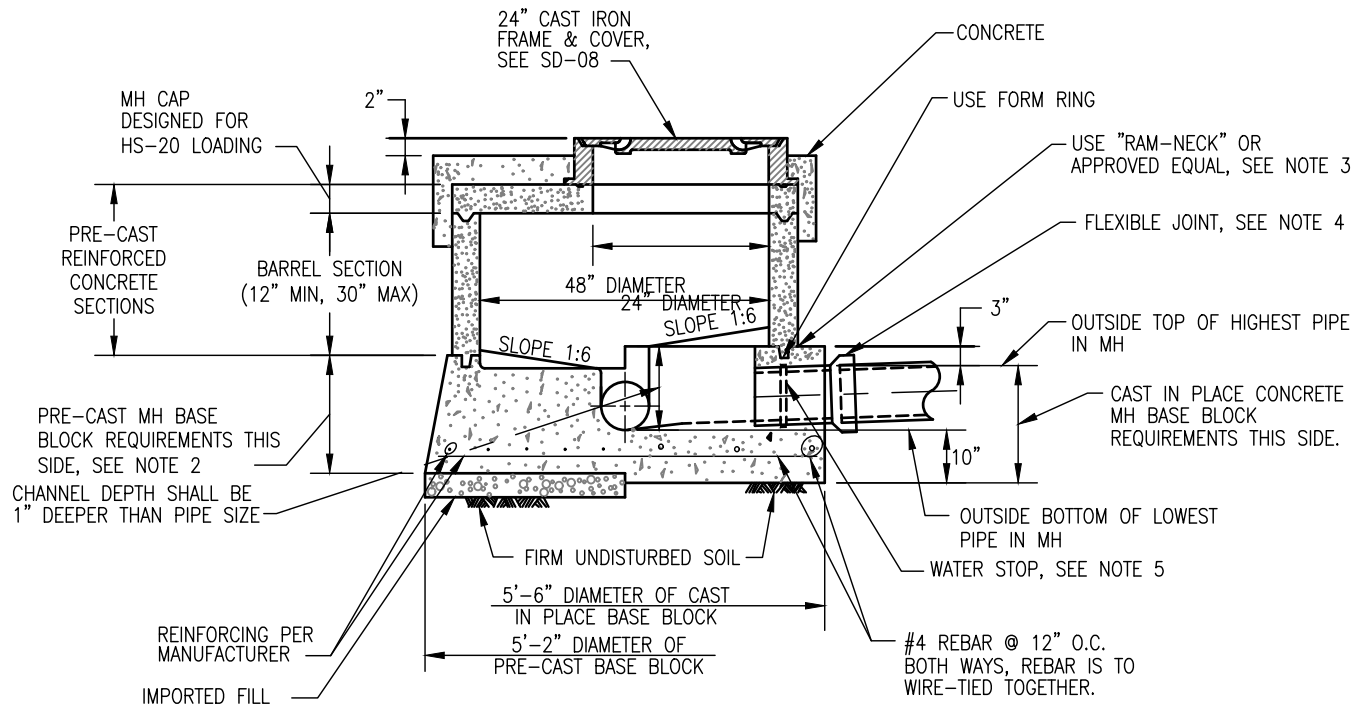

ELEVATION SECTION

NOTES:

1. ALL PRE-CAST UNITS SHALL BE MANUFACTURED AND TESTED IN ACCORDANCE WITH ASTM C478.
2. PRE-CAST MH BASE BLOCKS SHALL ONLY BE USED AFTER PRIOR APPROVAL HAS BEEN RECEIVED FROM THE ENGINEER FOR EACH LOCATION TO BE USED.
3. INSTALL "RAM-NECK" BETWEEN EACH JOINT OF THE CONE AND BARREL SECTIONS TO MAKE A FLEXIBLE WATER TIGHT JOINT. AFTER JOINT IS MADE, TRIM EXCESS RAM-NECK THEN GROUT JOINTS ON THE INSIDE AND OUTSIDE OF MH. AFTER GROUT HAS SET WRAP ALL OUTSIDE JOINTS WITH "RUB'R-NEK JOINT WRAP OR APPROVED EQUAL.
4. A FLEXIBLE JOINT IS REQUIRED ON 6", 8", 10", & 12" DIAMETER NON-PLASTIC PIPES. THE FLEXIBLE JOINT SHALL BE INSTALLED AS CLOSE AS POSSIBLE TO MH BASE BLOCK (6" MIN., 12" MAX.) TO PROVIDE PIPE FLEXIBILITY.
5. ON PLASTIC PIPES ENTERING OR LEAVING MH BASES:
 - 5.1. AN APPROVED WATER STOP SHALL BE INSTALLED. THE WATER STOP SHALL BE CENTERED UNDER THE MH WALL OR AS SHOWN.
 - 5.2. NON-SHRINK GROUT BLOCK SHALL BE PLACED AROUND PLASTIC PIPE AT THE MH BASE PENETRATION. BLOCK SHALL BE 12" IN LENGTH AND 12" THICKER THAN THE OUTSIDE DIAMETER OF THE PIPE, CENTERED ON THE PIPE.
6. TYPE 'A' SHALLOW MAIN MH MAYBE USED WHERE DISTANCE FROM TOP OF BASE TO BOTTOM OF FRAME IS BETWEEN 16" AND 30".

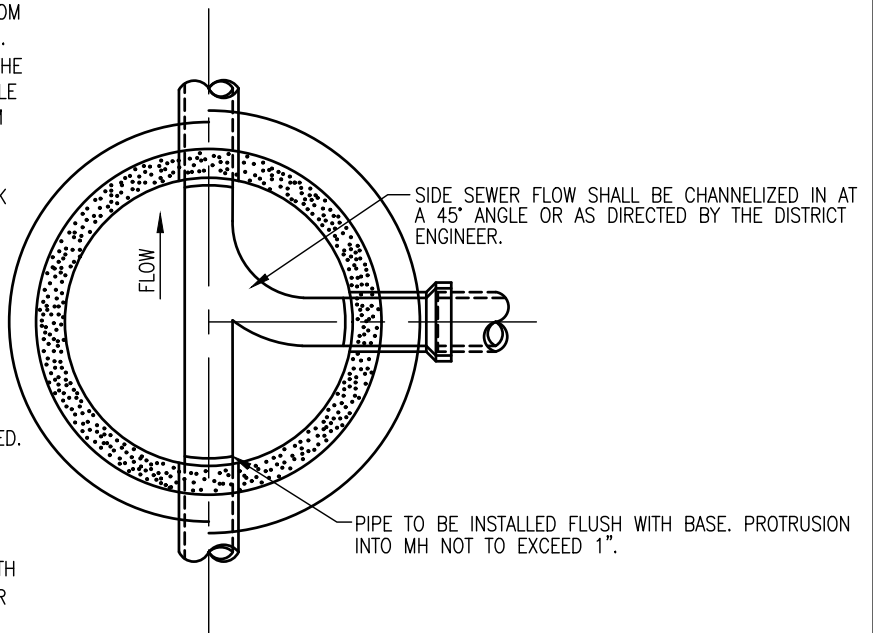

PLAN SECTION

DATE MARCH 2023 SHEET SD-06
 DRAWN JTD
 APPROVED [Signature]
 DISTRICT ENGINEER, RCE #68475



ORO LOMA SANITARY DISTRICT
 2600 GRANT AVENUE, SAN LORENZO, CA 94580

TYPE 'A'
 SHALLOW
 MAIN MH

NOTES:

1. PUMPED SYSTEMS SHALL ONLY BE PERMITTED IF A GRAVITY PATH IS NOT AVAILABLE. ALL PUMPED SYSTEMS MUST BE APPROVED IN WRITING BY THE DISTRICT ENGINEER.
2. PUMPED SYSTEMS SHALL BE E/ONE GRINDER PUMP SYSTEM OR EQUAL.
3. THE PROPERTY OWNER/DEVELOPER IS RESPONSIBLE FOR THE DESIGN OF THE PUMPED SYSTEM. THE FOLLOWING SHALL BE SUBMITTED TO THE DISTRICT FOR REVIEW AND APPROVAL:
 - 3.1. COMPLETE PLANS AND SPECIFICATIONS ON THE ENTIRE PUMPED SYSTEM.
 - 3.2. THE PLANS AND SPECIFICATIONS SHALL INCLUDE HOW THE PUMPED SYSTEM IS TO BE INSTALLED, GENERALLY THIS SHALL BE BASED OFF THE MANUFACTURER'S RECOMMENDATION.
 - 3.3. THE ELEVATION OF THE WET WELL AND THE DISCHARGE POINT SHALL BE CLEARLY INDICATED ON THE PLANS.
 - 3.4. THE CONTROL PANEL MUST CONTAIN AN AUDIBLE AND VISUAL ALARM SYSTEM THAT ALERTS THE RESIDENT IN THE EVENT OF FAILURE.
 - 3.5. PUMP CURVES SHOWING THAT THE SYSTEM WILL OPERATE PROPERLY.
 - 3.6. PLANS SHALL SHOW A TWO WAY CLEAN OUT BETWEEN THE STRUCTURE AND THE WET WELL.
 - 3.7. OPERATING PRESSURE OF THE PUMP SYSTEM, FORCE MAIN SHALL BE DESIGNED TO HANDLE A MINIMUM OF 1.5 TIMES THE OPERATING PRESSURE.
4. PUMP SHALL BE A GRINDER PUMP.
5. THE WET WELL SHALL NOT BE INSTALLED WITHIN THE STRUCTURE OR BUILDING.
6. THE FORCE MAIN SHALL NOT PASS THROUGH OR DISCHARGE INTO ANY STRUCTURE OR BUILDING.
7. THE PUMP DISCHARGE SHALL TRANSITION TO A MINIMUM 4-INCH GRAVITY SEWER, VIA A CLEAN OUT, AT OR BEFORE THE PROPERTY LINE, AND A MINIMUM OF 6- FEET FROM THE DISTRICT'S MAIN.
 - 7.1. FOR PRIVATELY OWNED COLLECTOR SEWER OR ADU: THE PUMP DISCHARGE MAY CONNECT TO THE COLLECTOR SEWER DOWNSTREAM OF ALL GRAVITY CONNECTIONS AND THE BUILDING SEWER BACKWATER PREVENTION SYSTEM.
 - 7.2. CLEAN OUT SHALL BE INSTALLED PER DISTRICT STANDARDS.
 - 7.3. PUMP DISCHARGE TRANSITION SHALL NOT BE INSTALLED IN PUBLIC STREETS OR SIDEWALKS WITHOUT APPROVAL.
 - 7.4. CLEAN OUT SHALL BE PROTECTED BY A BOX. APPROVED BOXES ARE:
 - 7.1.1. CHRISTY F08 OR EQUAL IN NON-VEHICULAR TRAFFIC AREAS.
 - 7.1.2. CHRISTY G03 OR EQUAL IN VEHICULAR TRAFFIC AREAS WITH METAL LID.
 - 7.1.3. LID SHALL BE MARKED SEWER OR WITH S.
8. THE DISTRICT DOES NOT ALLOW SAND OR PEA GRAVEL TO BE USED AS A BACKFILL MATERIAL, SEE STANDARD DETAIL 16.
9. THE FORCE MAIN SHALL BE HYDRAULICALLY PRESSURE TESTED AT 1.5 TIMES THE OPERATING PRESSURE. THE FORCE MAIN SHALL HOLD THE PRESSURE CONSTANT FOR 2 HOURS.
 - 9.1. AIR COMPRESSORS SHALL NOT BE USED IN PRESSURE TEST.

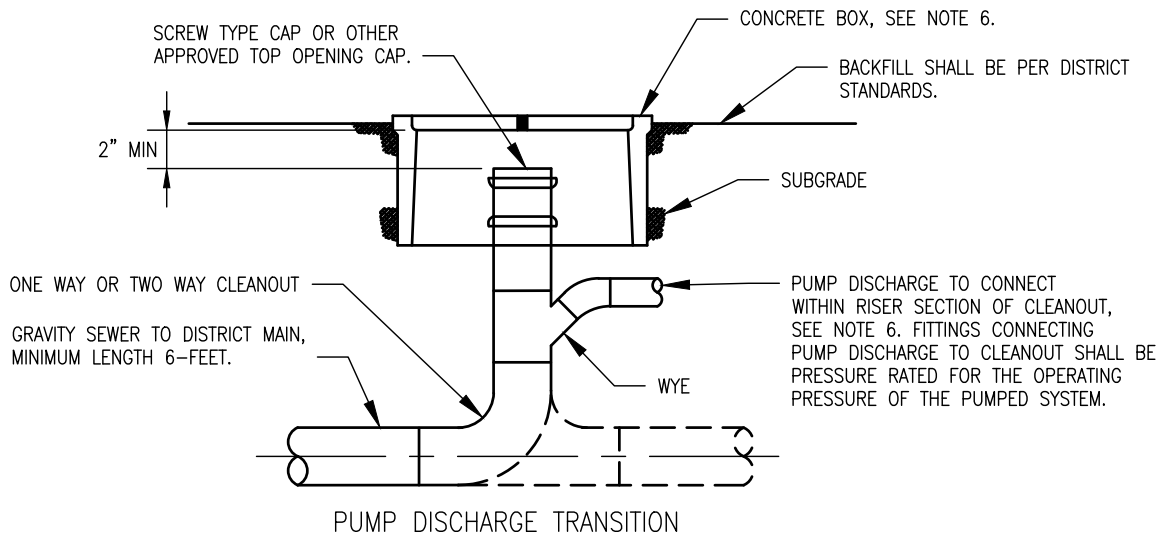

DATE NOV 2024 SHEET SD-07
 DRAWN WDH
 APPROVED [Signature]
 DISTRICT ENGINEER, RCE #68475



ORO LOMA SANITARY DISTRICT
 2600 GRANT AVENUE, SAN LORENZO, CA 94580

PUMPED SYSTEMS

NOTES:

- A. FRAME AND COVERS INSTALLED ON MHS IN NON-PAVED EASEMENTS SHALL BE MANUFACTURED BY EJ USA, INC. PRODUCT NO. COM260252A01 SUPPLIED BY 3T EQUIPMENT COMPANY, INC., ROHNERT PARK, CA, 707-543-8555, NO EQUAL. COVERS SHALL BE EQUIPPED WITH A LOCK AND LOCKING TOOL MODEL NO. "TwistLIFT" MANUFACTURED BY TITUS INDUSTRIAL GROUP.
- B. FRAME AND COVERS INSTALLED ON MHS IN PAVED RIGHT OF WAYS SHALL BE MANUFACTURED BY D&L SUPPLY COMPANY, MODEL NO. A-1024, OR APPROVED EQUAL.
 - 1. MINOR MODIFICATIONS IN DIMENSIONS AND MANUFACTURING CONFIGURATIONS ARE PERMISSIBLE SUBJECT TO ENGINEER'S APPROVAL.
 - 2. CAST IRON FOR FRAME AND COVER SHALL BE CLASS 30 MINIMUM AS PER ASTM A-48.
 - 3. RAISED LETTERS 1/4" HIGH TO BE CAST IN CENTER OF MH.
 - 4. BEFORE LEAVING THE FOUNDRY, THE FRAME AND COVER SHALL BE PAINTED WITH OR DIPPED IN ASPHALT PAINT.
 - 5. COVER MAY BE FURNISHED WITH OR WITHOUT RIBS BUT MUST BE DESIGNED FOR H-20 LOADING.

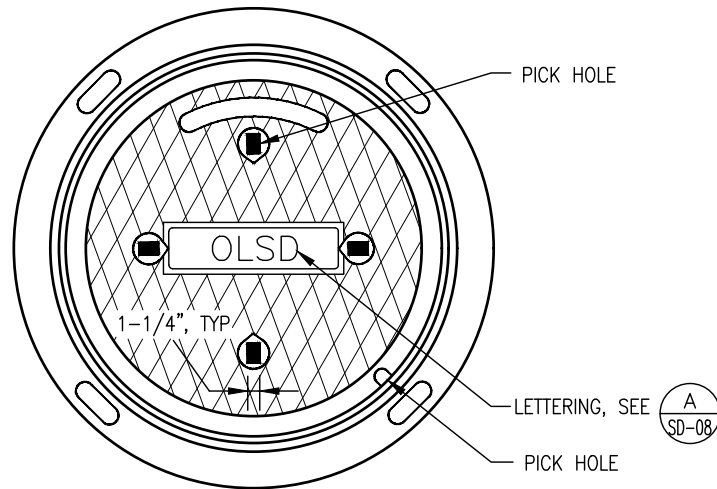

CAST IRON FRAME AND COVER PLAN

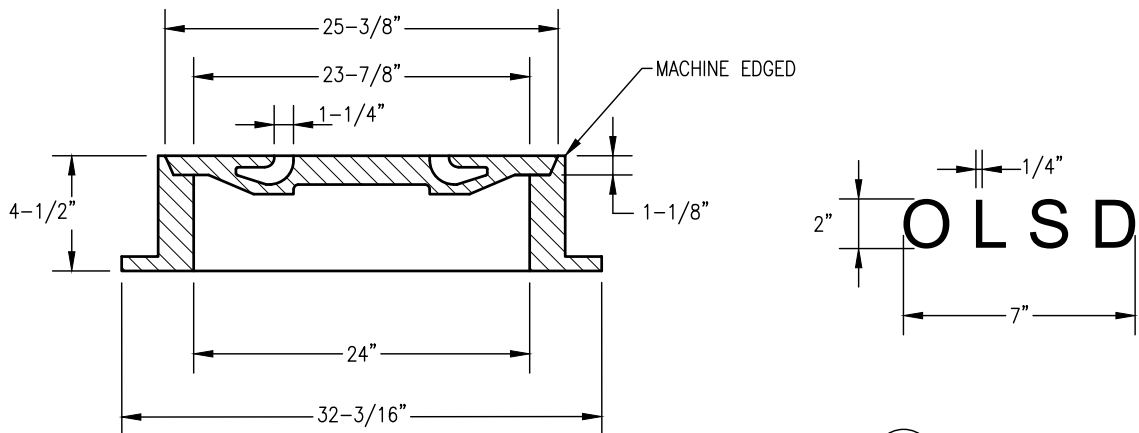

CAST IRON FRAME AND COVER ELEVATION SECTION

A
SD-08 LETTERING
NO SCALE

DATE OCT 2019 SHEET SD-08
 DRAWN MPS
 APPROVED [Signature]
 DISTRICT ENGINEER, RCE #68475



ORO LOMA SANITARY DISTRICT
 2600 GRANT AVENUE, SAN LORENZO, CA 94580

24" MH
 FRAME AND
 COVER

STREET WORK NOTES:

1. THE FRAME AND COVER SHALL BE MODEL RE24R8FS MANUFACTURED BY PAMREX, INC. OR APPROVED EQUAL.
2. DUCTILE IRON FOR FRAME AND COVER SHALL COMPLY WITH ASTM A536-80.
3. BEFORE LEAVING THE FOUNDRY, THE FRAME AND COVER SHALL BE BITUMINOUS COATED.
4. THE CASTING SHALL MEET OR EXCEED AASHTO H-20 LOAD REQUIREMENTS AND FEDERAL SPECIFICATION RR-F621-C.
5. THE COVER SHALL HAVE A HINGED COVER WITH A LOCK DOWN SYSTEM, THE SEAT SHALL HAVE AN INTEGRAL POLYETHYLENE GASKET THAT IS REPLACEABLE, AND THE COVER SHALL BE INSTALLED WITHOUT THE ANTI-THEFT LOCKING KEY.
6. MINOR MODIFICATIONS ARE PERMISSIBLE SUBJECT TO DISTRICT ENGINEER'S APPROVAL.

EASEMENT NOTES:

1. THE FRAME AND COVER SHALL BE MODEL 2600-XXX MANUFACTURED BY GMI COMPOSITES, INC. MUSKEGON, MI, (800) 330-4045, OR APPROVED EQUAL.
2. THE CASTING SHALL MEET OR EXCEED AASHTO H-20 LOAD REQUIREMENTS AND FEDERAL SPECIFICATION RR-F621-C.
3. THE COVER SHALL HAVE A LOCK DOWN SYSTEM, THE SEAT SHALL HAVE AN INTEGRAL POLYETHYLENE GASKET THAT IS REPLACEABLE, AND THE COVER SHALL BE INSTALLED WITHOUT THE ANTI-THEFT LOCKING KEY.
4. MINOR MODIFICATIONS ARE PERMISSIBLE SUBJECT TO DISTRICT ENGINEER'S APPROVAL.

DATE APRIL 2013 SHEET SD-09
DRAWN JTD
APPROVED 
DISTRICT ENGINEER, RCE #68475



ORO LOMA SANITARY DISTRICT
2600 GRANT AVENUE, SAN LORENZO, CA 94580

24" MH
LOCKING FRAME
AND COVER

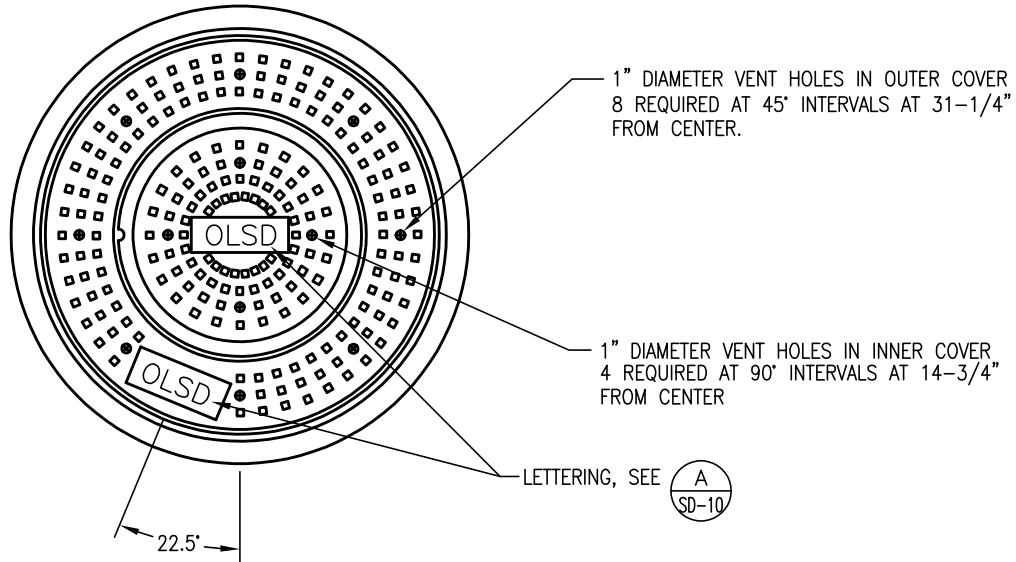

PLAN

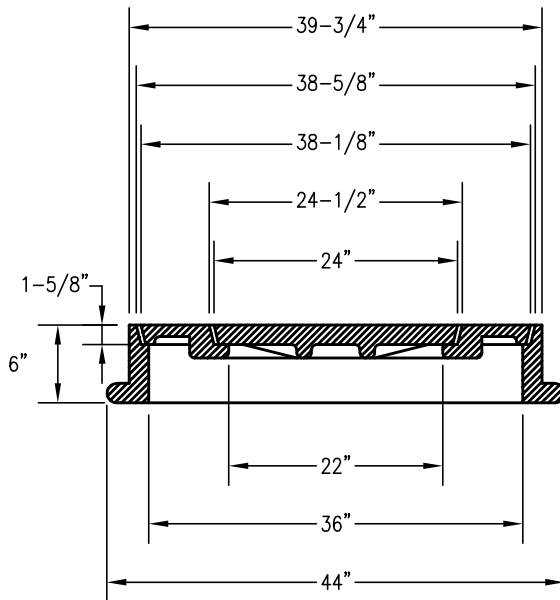

ELEVATION SECTION

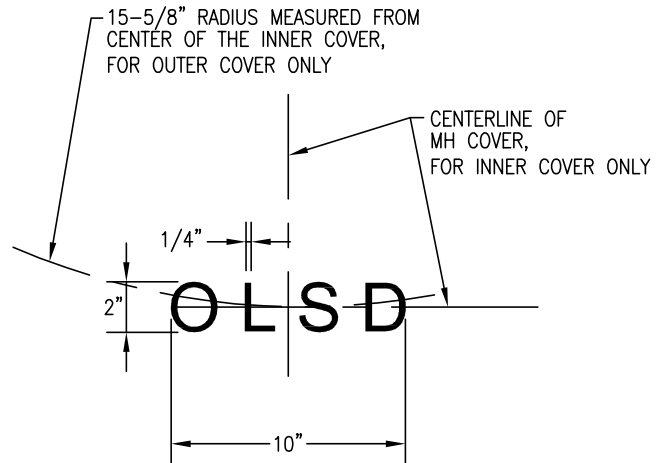

(A) LETTERING
SD-10 NO SCALE

NOTES:

1. MINOR MODIFICATIONS IN ABOVE DIMENSIONS AND MANUFACTURING CONFIGURATIONS ARE PERMISSIBLE SUBJECT TO ENGINEER'S APPROVAL.
2. CAST IRON FOR FRAME AND COVER SHALL BE CLASS 30 MINIMUM AS PER ASTM A-48.
3. RAISED LETTERS 1/4" HIGH TO BE CAST IN CENTER OF MH.
4. BEFORE LEAVING THE FOUNDRY, THE FRAME AND COVER SHALL BE PAINTED OR DIPPED IN ASPHALT PAINT.
5. COVER MAY BE FURNISHED WITH OR WITHOUT RIBS BUT MUST BE DESIGNED FOR HS-20 LOADING.

DATE MARCH 2023 SHEET SD-10
DRAWN WDH
APPROVED *[Signature]*
DISTRICT ENGINEER, RCE #68475



ORO LOMA SANITARY DISTRICT
2600 GRANT AVENUE, SAN LORENZO, CA 94580

36" MH
FRAME AND
COVER

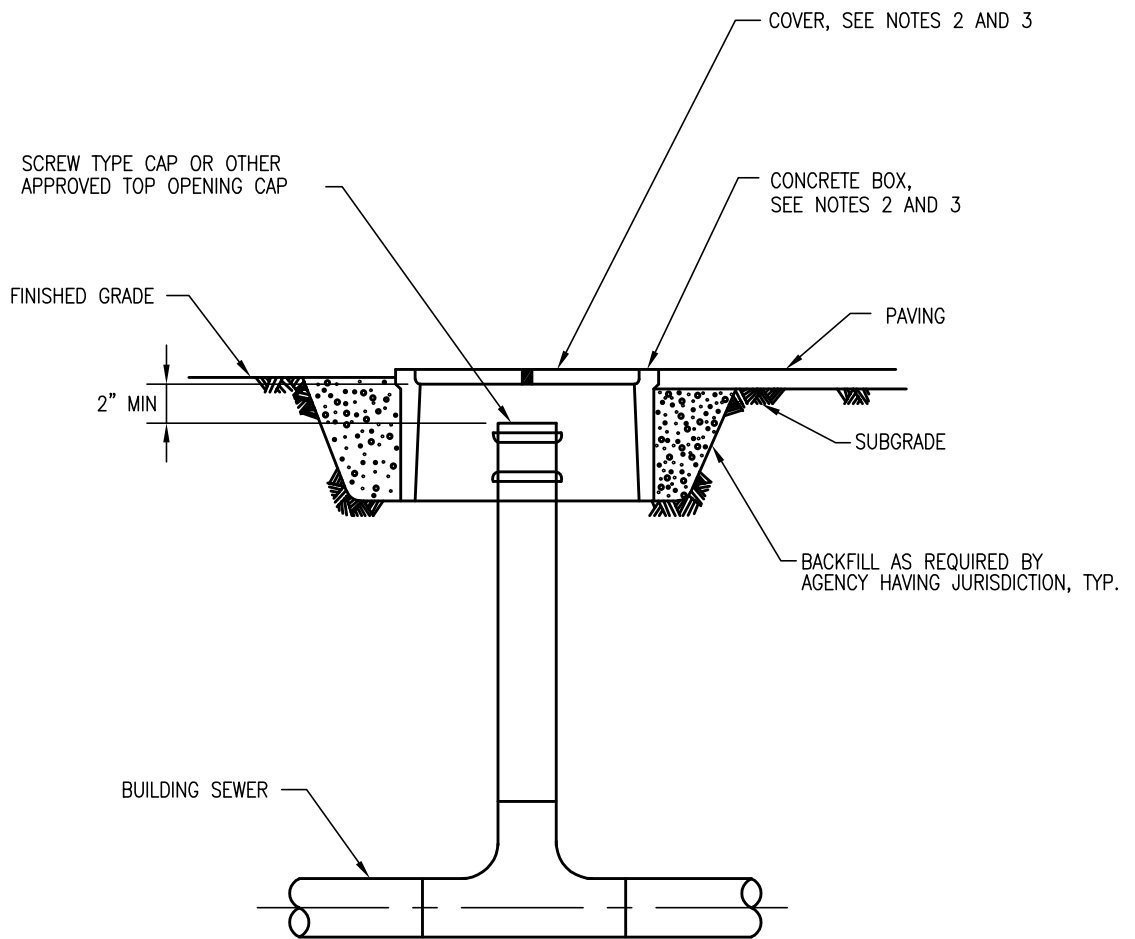

NOTES:

1. TERMINATE CLEANOUT AT CLOSEST JOINT TO SURFACE WITH TEMPORARY PLUG. AFTER ALL BACKFILL IS COMPLETE AND SUB-GRADE MADE IN AREAS TO BE PAVED THE FINAL RISER PIPE AND BOX SHALL BE INSTALLED AS SHOWN.
2. CLEANOUT SHALL BE PROTECTED BY A BOX. CLEANOUTS SHALL NOT BE INSTALLED IN PUBLIC STREETS OR SIDEWALKS WITHOUT APPROVAL.
3. APPROVED BOXES ARE:
 - 3.1. CHRISTY F08 OR EQUAL IN NON-VEHICULAR TRAFFIC AREAS.
 - 3.2. CHRISTY G03 OR EQUAL IN VEHICULAR TRAFFIC AREAS, WITH METAL LID
 - 3.3. ALL CLEANOUT BOX LIDS SHALL BE MARKED WITH A LETTER "S" OR THE WORD "SEWER".
4. CLEANOUT PIPE SHALL BE OF THE SAME MATERIAL AND SIZE AS DOWNSTREAM PIPE.

DATE APRIL 2022	SHEET SD-11
DRAWN WDH	
APPROVED <i>[Signature]</i>	
DISTRICT ENGINEER, RCE # 68475	



ORO LOMA SANITARY DISTRICT
2600 GRANT AVENUE, SAN LORENZO, CA 94580

BUILDING SEWER
CLEANOUT
TO GRADE

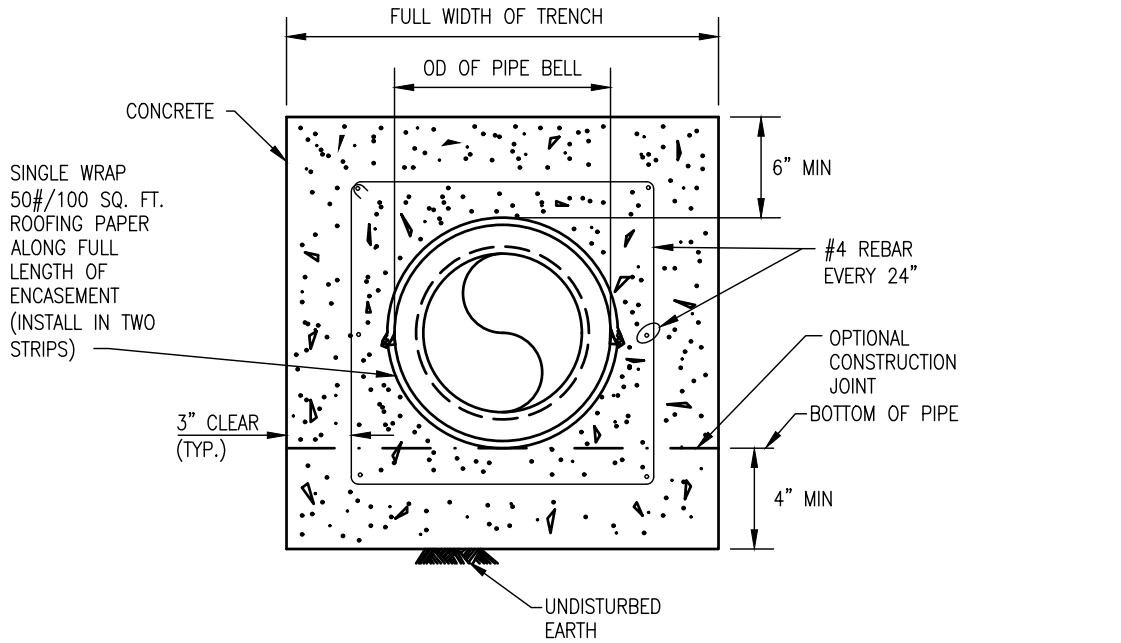

CONCRETE ENCASEMENT

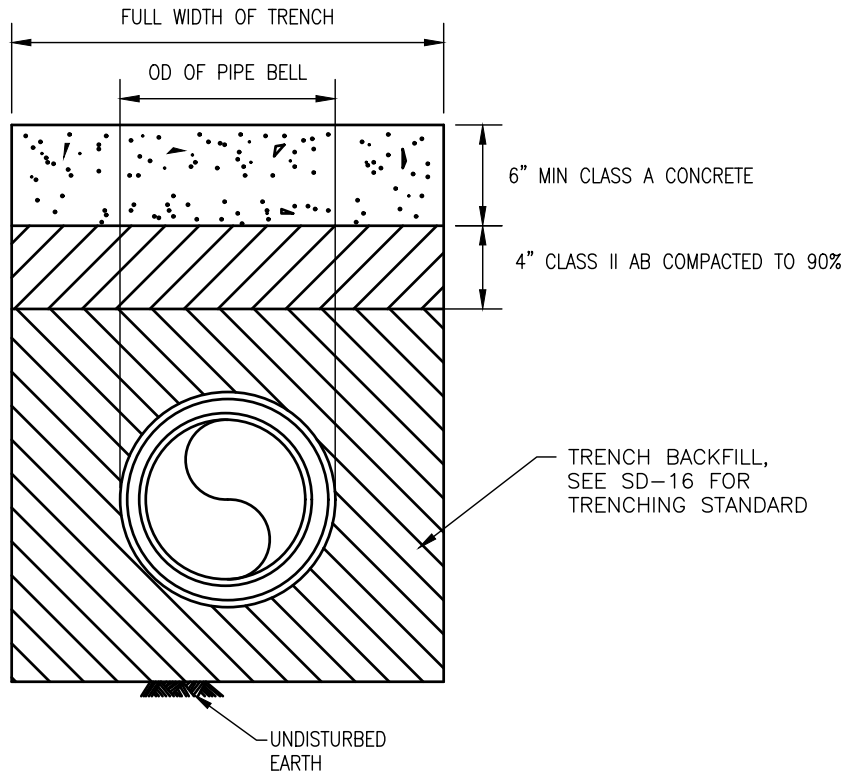

CONCRETE CAP

NOTES:

1. APPROVAL FROM OLSD ENGINEERING DEPARTMENT REQUIRED BEFORE USE.
2. ALL REINFORCING SHALL BE #4 BARS AS SHOWN.
3. EACH JOINT SHALL BE TIED DOWN TO PREVENT FLOATING USING A METHOD APPROVED BY THE ENGINEER.

DATE APRIL 2013 SHEET SD-12
 DRAWN JTD
 APPROVED [Signature]
 DISTRICT ENGINEER, RCE #68475



ORO LOMA SANITARY DISTRICT
 2600 GRANT AVENUE, SAN LORENZO, CA 94580

**CONCRETE ENCASEMENT/
 CAP**

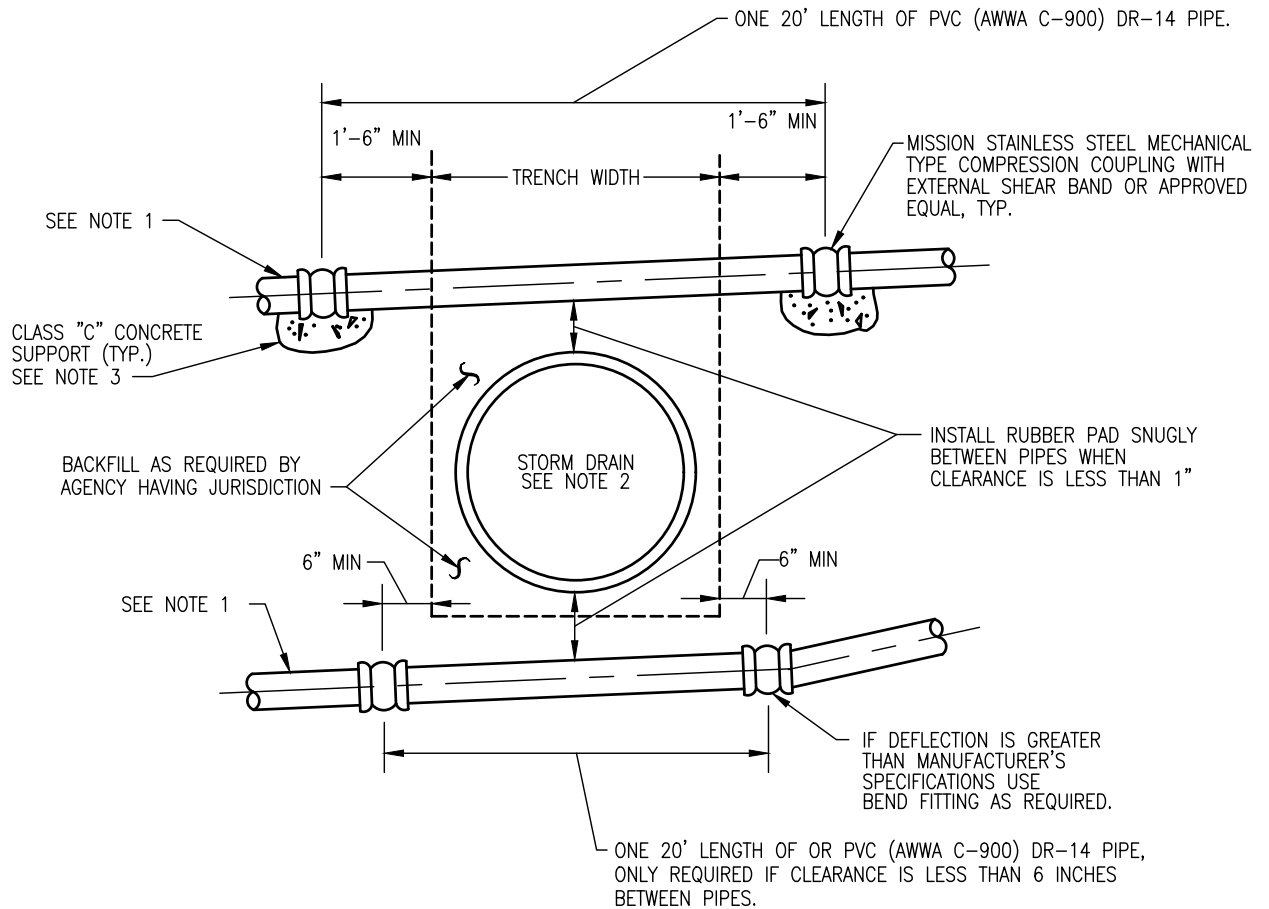

NOTES:

1. THE ABOVE DETAIL IS TYPICAL FOR MAIN AND BUILDING SEWERS WHEN VCP OR PLASTIC PIPE MATERIALS ARE USED.
2. THIS TYPE OF CONNECTION MAY BE REQUIRED BY THE DISTRICT WHEN CROSSING CERTAIN OTHER UTILITIES.
3. CLASS "C" CONCRETE SHALL CONFORM TO THE STANDARD SPECIFICATIONS.

DATE APRIL 2013 SHEET SD-13
 DRAWN JTD
 APPROVED *[Signature]*
 DISTRICT ENGINEER, RCE #68475



ORO LOMA SANITARY DISTRICT
 2600 GRANT AVENUE, SAN LORENZO, CA 94580

SANITARY SEWER
 STORM DRAIN
 CROSSING

ONE 20' LENGTH OF PVC (AWWA C-900) DR-14
PRESSURE PIPE CENTERED OVER UTILITY.

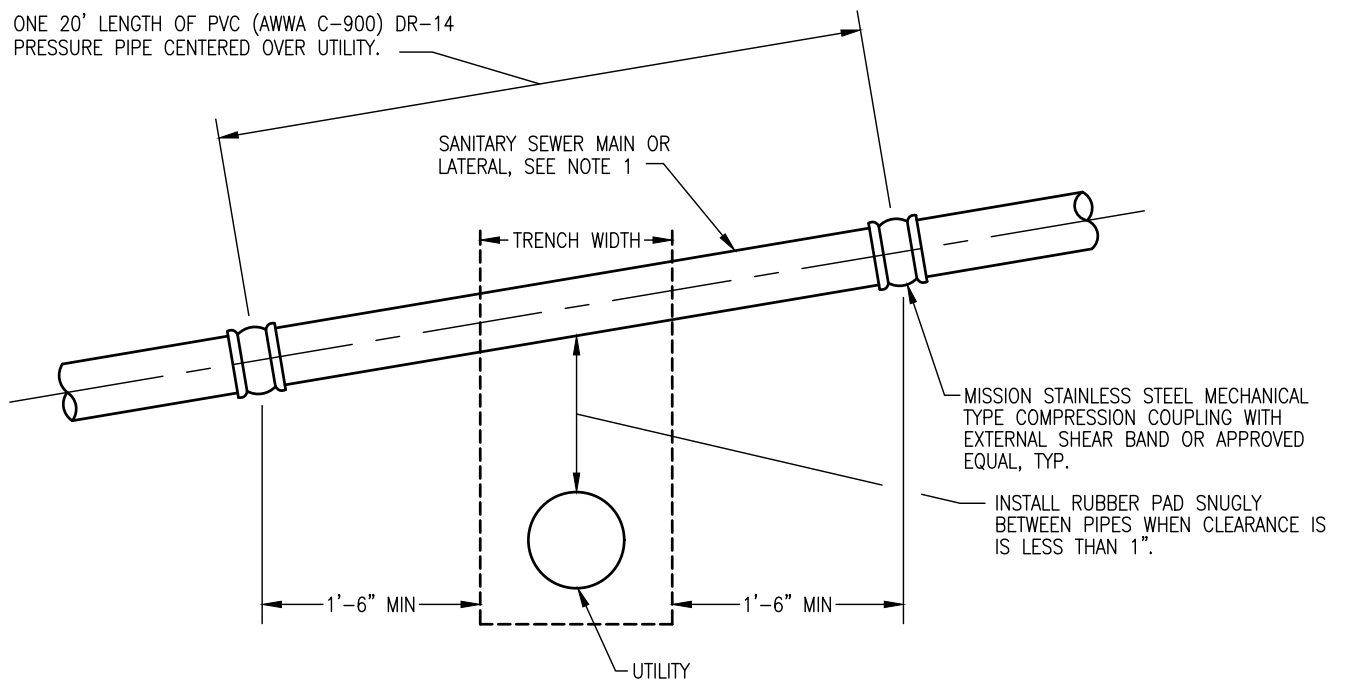

TYPICAL CROSSING OVER UTILITY PIPE

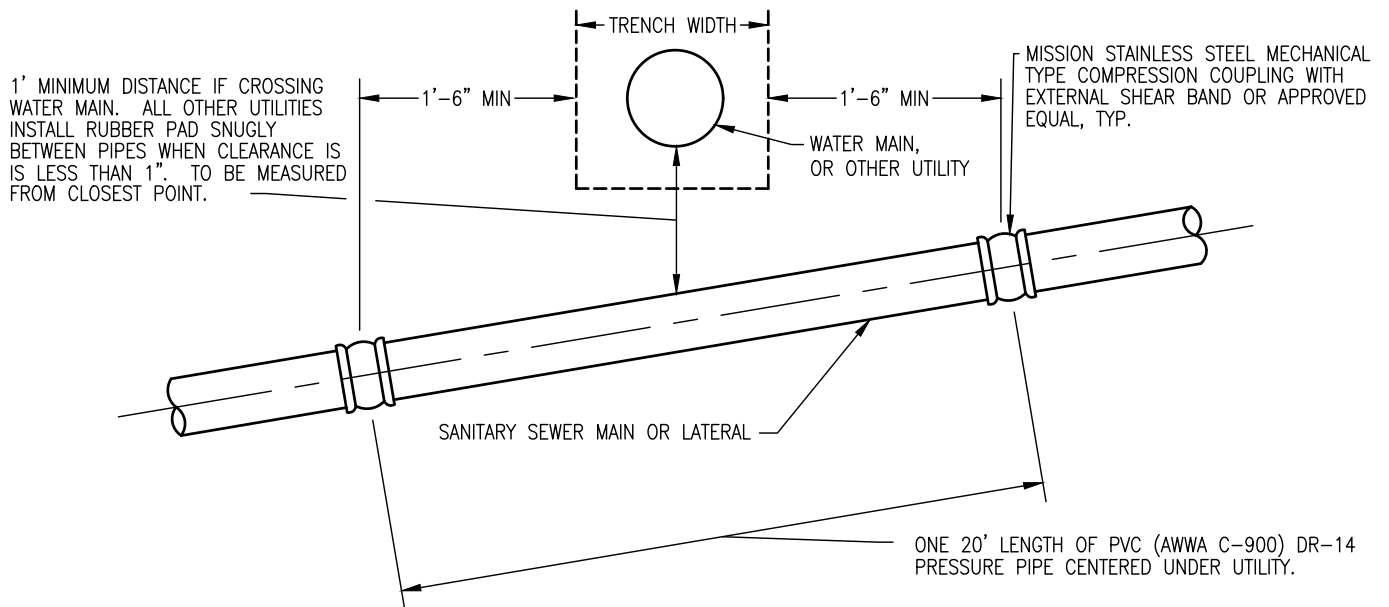

TYPICAL CROSSING UNDER UTILITY PIPE

NOTES:

- SEWER MAY NOT CROSS OVER WATER MAIN WITHOUT OLSD ENGINEERING DEPARTMENT APPROVAL.

DATE APRIL 2013 SHEET SD-14
 DRAWN JTD
 APPROVED [Signature]
 DISTRICT ENGINEER, RCE #68475



ORO LOMA SANITARY DISTRICT
 2600 GRANT AVENUE, SAN LORENZO, CA 94580

UTILITY
CROSSING

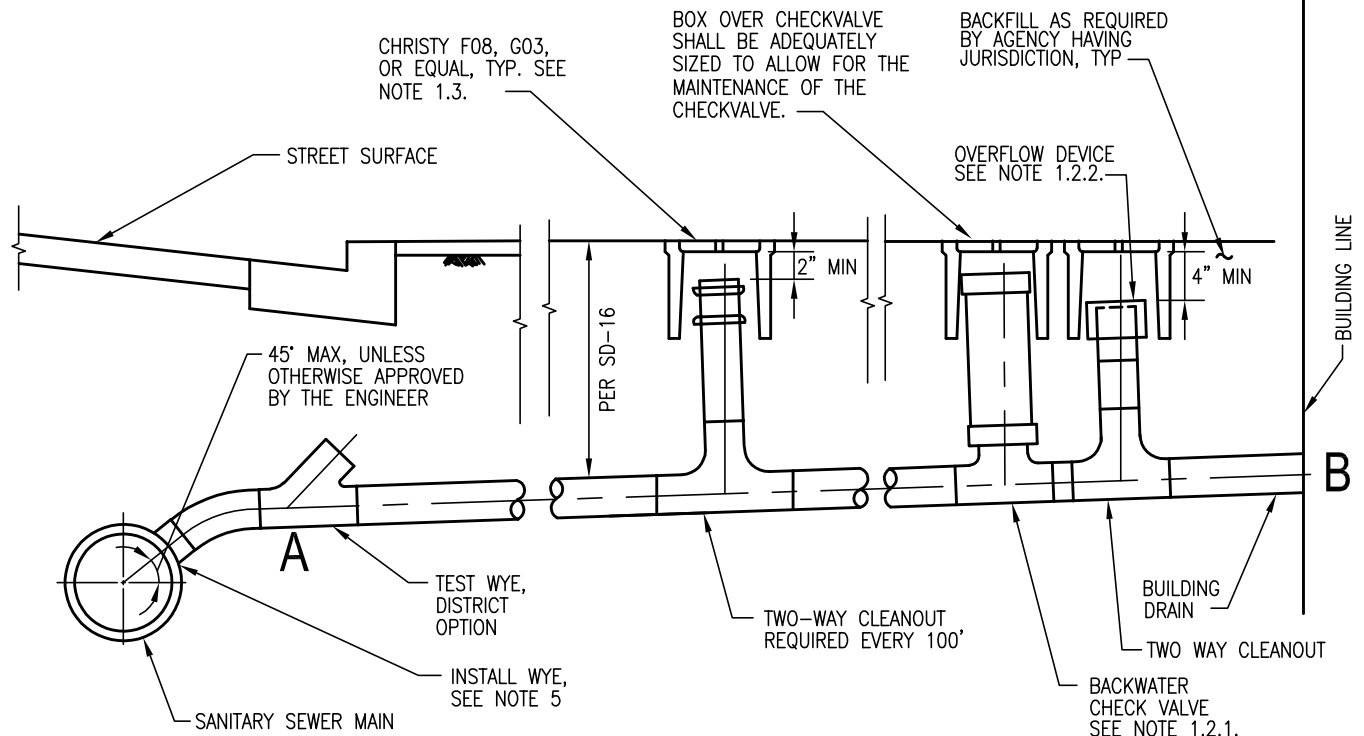

NOTES:

1. BACKWATER PREVENTION SYSTEM (BPS) SHALL INCLUDE A BACKWATER CHECKVALVE, A TWO WAY CLEANOUT, AND AN OVERFLOW DEVICE INSTALLED ON THE CLEANOUT. OTHER TYPES OF BACKWATER PREVENTION DEVICES MAY BE APPROVED BY THE ENGINEER.
 - 1.1. A BACKWATER PREVENTION SYSTEM IS REQUIRED AS FOLLOWS:
 - 1.1.1. ON ALL NEW BUILDING STRUCTURES.
 - 1.1.2. ON ALL EXISTING STRUCTURES REQUIRING LATERAL REPAIR.
 - 1.2. A BACKWATER PREVENTION SYSTEM SHALL BE CONSTRUCTED AS FOLLOWS:
 - 1.2.1. A BACKWATER CHECKVALVE SHALL BE INSTALLED IMMEDIATELY DOWNSTREAM OF THE BUILDING SEWER CLEANOUT AND SHALL BE THE SAME INSIDE DIAMETER AS THE BUILDING SEWER PIPE. IF THE TOP OF THE LATERAL IS 18" OR GREATER IN DEPTH FROM THE FINISH SURFACE THE BACKWATER CHECKVALVE SHALL BE A RECTORSEAL "CLEAN CHECK" EXTENDABLE BACKWATER VALVE OR APPROVED EQUAL. IF THE TOP OF THE LATERAL IS LESS THAN 18" IN DEPTH THE BACKWATER CHECKVALVE SHALL BE AN "N.D.S. 475" OR APPROVED EQUAL.
 - 1.2.2. THE OVERFLOW DEVICE SHALL THEN BE INSTALLED ON THE BUILDING SEWER CLEANOUT. THE OVERFLOW DEVICE SHALL BE A "SEWER POPPER" PART NO. S62-304 MADE BY JONES STEPHENS CO. OR APPROVED EQUAL. OVERFLOW DEVICE SHALL BE INSTALLED IN SUCH A MANNER THAT IT WILL PROPERLY FUNCTION.
 - 1.3. THE CHECKVALVE AND CLEANOUT(S) SHALL BE PROVIDED WITH SUITABLE BOXES SET TO FINISHED GRADE PROVIDING FOR SERVICE ACCESSIBILITY AND PROPER OPERATION. BOXES SHALL BE STACKED ON TOP OF EACH OTHER IF NECESSARY TO PROVIDE PROTECTION TO THE BACKWATER CHECKVALVE AND THE BACKWATER OVERFLOW DEVICE. BOXES SET IN TRAFFIC AREAS SHALL BE TRAFFIC RATED AND BOXES SHALL NOT BE SET IN PUBLIC STREETS OR SIDEWALKS WITHOUT APPROVAL.
2. LATERAL IS TO BE PLACED IN A STRAIGHT LINE WITH NO BENDS FROM POINT A TO B, UNLESS OTHERWISE APPROVED BY THE ENGINEER.
3. COMPLIANCE WITH THE CALIFORNIA UNIFORM PLUMBING CODE IS REQUIRED.
4. THE BACKWATER PREVENTION SYSTEM IS A PART OF THE PRIVATE SEWER. REPAIR AND MAINTENANCE IS THE RESPONSIBILITY OF THE PROPERTY OWNER.
5. NEW WYE SHALL BE 45-DEGREES OF THE SAME MATERIAL AS THE MAIN. TEE IS NOT ALLOWED. WYE PLACED ON AN HDPE MAIN SHALL BE HDPE AND FUSED IN PLACE. FUSION SADDLES SHALL BE DE-BURRED AND THE DRILLED PLUG SHALL BE SURRENDERED TO THE INSPECTOR.
6. ALL HDPE TO HDPE JOINTS SHALL BE FUSED, ALL INSIDE BEADS SHALL BE REMOVED AND SURRENDERED TO THE INSPECTOR.

DATE AUGUST 2023 SHEET SD-15
 DRAWN WDH
 APPROVED [Signature]
 DISTRICT ENGINEER, RCE # 68475



ORO LOMA SANITARY DISTRICT
 2600 GRANT AVENUE, SAN LORENZO, CA 94580

BUILDING SEWER/
 BACKWATER PRE-
 VENTION SYSTEM

TRENCH BEDDING, SHADING AND COVER REQUIREMENTS FOR SEWER INSTALLATION

PIPE COVER LIMITATION TABLE		
PIPE SPECIFICATION - SEE SECTION 3		COVER IN FEET MIN. - MAX. *
MATERIAL	TYPE AND MINIMUM CLASS	
MAIN AND BUILDING SEWERS IN PUBLIC RIGHT OF WAYS AND PAVED PRIVATE PROPERTY		
4" - Larger VCP		3.0 - 19
4" - Larger Plastic	Solid & Composite Wall	3.0 - 30
4" - Larger CIP	Service Weight	2.5 - 30
4" - Larger CIP	Extra Heavy	2.0 - 30
4" - Larger DIP	Class 50 & 51	0.5 - 30
BUILDING SEWER FROM PROPERTY LINE TO BUILDING IN UNPAVED PRIVATE PROPERTY		
4" - 6" VCP	Extra Strength	1.0 - 30
4" - 6" Plastic	Solid & Composite Wall	1.0 - 30
4" - 6" CIP	Service Weight	1.0 - 30
4" - 6" CIP	Extra Heavy	0.5 - 30
4" - 6" DIP	Class 50 & 51	0.0 - 30

* WHEN MAXIMUM COVER IS EXCEEDED, SPECIAL BEDDING REQUIREMENTS AND APPROVAL BY THE DISTRICT ENGINEER IS NECESSARY.

NOTES:

1. IF NATIVE MATERIAL IS FOUND TO BE UNSUITABLE, THE UNSUITABLE MATERIAL SHALL BE EXCAVATED TO A MINIMUM OF 12" AND 3/4" CRUSHED ROCK SHALL BE PLACED WRAPPED IN FILTER FABRIC. FILTER FABRIC SHALL BE ROLLED OUT IN THE TRENCH, 3/4" CRUSHED ROCK SHALL BE PLACED THEN THE ENDS SHALL BE WRAPPED AROUND THE ROCK WITH A MINIMUM OF 18" OVERLAP.
2. BEDDING SHALL BE 3/4" CRUSHED ROCK AND SHALL BE CLEAN AND FREE OF DELETERIOUS SUBSTANCES. BEDDING SHALL BE MECHANICALLY COMPACTED TO 95% RELATIVE COMPACTION.
 - 2.1. BEDDING SHALL BE SCOOPED OUT FROM UNDER PIPE BELLS TO PREVENT UNNECESSARY STRESS ON THE PIPE; PIPE BELLS SHALL BE SUPPORTED BY THE BEDDING.
3. PIPE SHADING SHALL BE 3/4" CRUSHED ROCK AND SHALL BE CLEAN AND FREE OF DELETERIOUS SUBSTANCES. ROCK SHALL BE PLACED IN 6" LIFTS AND CONSOLIDATED TIGHTLY USING A ROD OR SHOVEL.
4. TRENCH BACKFILL SHALL BE AS SPECIFIED BY PUBLIC AGENCY HAVING JURISDICTION OR:
 - 4.1. IN PAVED AND UNPAVED ROADS CLASS 2 AB SHALL BE PLACED AND MECHANICALLY COMPACTED TO 95% RELATIVE COMPACTION.
 - 4.2. IN UNPAVED NON-ROAD AREAS NATIVE MATERIAL SHALL BE PLACED AND MECHANICALLY COMPACTED TO 85% RELATIVE COMPACTION.
5. SURFACE SHALL BE AS SPECIFIED BY PUBLIC AGENCY HAVING JURISDICTION OR:
 - 5.1. IN UNPAVED ROADS, CLASS 2 AB SHALL BE PLACED AND MECHANICALLY COMPACTED TO 95% RELATIVE COMPACTION.
 - 5.2. IN UNPAVED NON-ROAD AREAS, SURFACE SHALL BE RESTORED TO ORIGINAL CONDITION USING SIMILAR MATERIALS. ALL LOOSE MATERIAL SHALL BE MECHANICALLY COMPACTED TO 85% RELATIVE COMPACTION.
 - 5.3. IN PAVED ROADS (REQUIREMENTS MAY BE CHANGED BY PUBLIC AGENCY HAVING JURISDICTION):
 - 5.3.1. STANDARD TEE CUT SHALL BE USED. INITIALLY SAW CUT AC EVEN WITH THE EXCAVATION WALLS. MAKE FINAL SAW CUT FOR TEE SECTION IMMEDIATELY PRIOR TO PAVING. SAW CUTS FOR TEE SECTION SHALL BE THE FULL THICKNESS OF THE EXISTING PAVEMENT. STANDARD TEE SECTION IS 12" BEYOND EXCAVATION WALLS, THE PUBLIC AGENCY HAVING JURISDICTION MAY REQUIRE A WIDER TEE SECTION.
 - 5.3.2. AFTER REMOVAL OF TEE SECTION AC, THE SUBGRADE SHALL BE MECHANICALLY COMPACTED TO 95% RELATIVE COMPACTION. AC SECTION SHALL BE 12" THICK OR AS SPECIFIED BY PUBLIC AGENCY HAVING JURISDICTION.
 - 5.3.3. AC SHALL BE AS SPECIFIED BY PUBLIC AGENCY HAVING JURISDICTION OR TYPE A, 1/2" MAX, MEDIUM GRADING.
6. SAND AND PEA GRAVEL SHALL NOT BE USED IN FOUNDATION, BEDDING, SHADING, BACKFILL, OR SURFACE WITHOUT WRITTEN PERMISSION FROM THE DISTRICT ENGINEER.

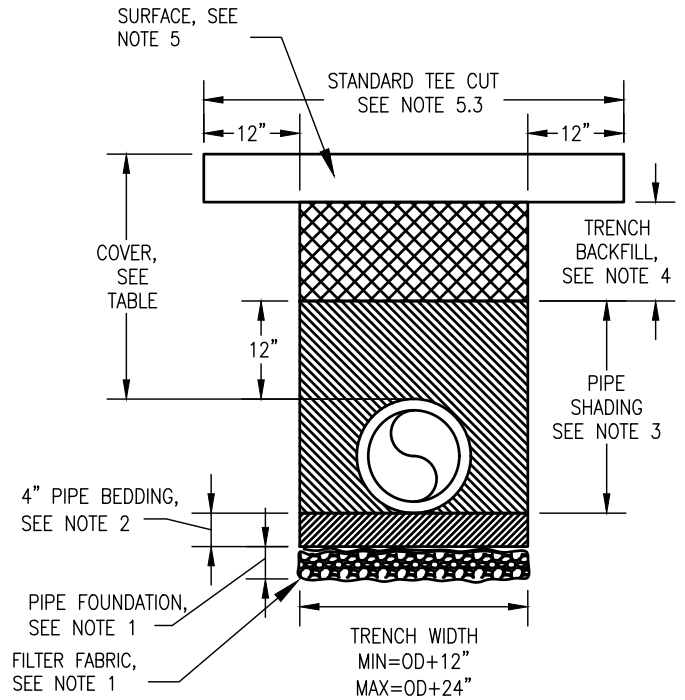

DATE APRIL 2013 SHEET SD-16
 DRAWN JTD/WDH
 APPROVED *[Signature]*
 DISTRICT ENGINEER, RCE #68475



ORO LOMA SANITARY DISTRICT
 2600 GRANT AVENUE, SAN LORENZO, CA 94580

TYPICAL
 TRENCH

CAP SHALL BE INSTALLED HERE ON THE TAP OR WYE, CAP SHALL BE VISIBLE FROM THE INSIDE OF THE PIPE DURING THE DISTRICT'S ROUTINE CCTV INSPECTION.

PRIVATE SEWER TO BE ABANDONED

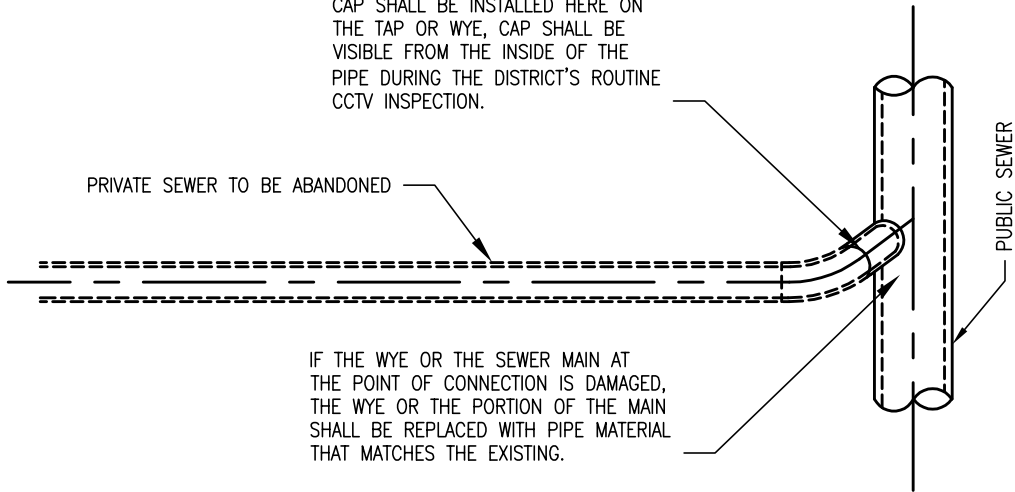

IF THE WYE OR THE SEWER MAIN AT THE POINT OF CONNECTION IS DAMAGED, THE WYE OR THE PORTION OF THE MAIN SHALL BE REPLACED WITH PIPE MATERIAL THAT MATCHES THE EXISTING.

PLAN

PRIVATE SEWER TO BE ABANDONED

PLUG AS REQUIRED IN THIS AREA WITH FLEXIBLE COUPLING, EXPANDABLE PLUG, OR APPROVED EQUAL.

FITTING (WYE OR TEE) ON PUBLIC SEWER IN STREET OR EASEMENT

PUBLIC SEWER

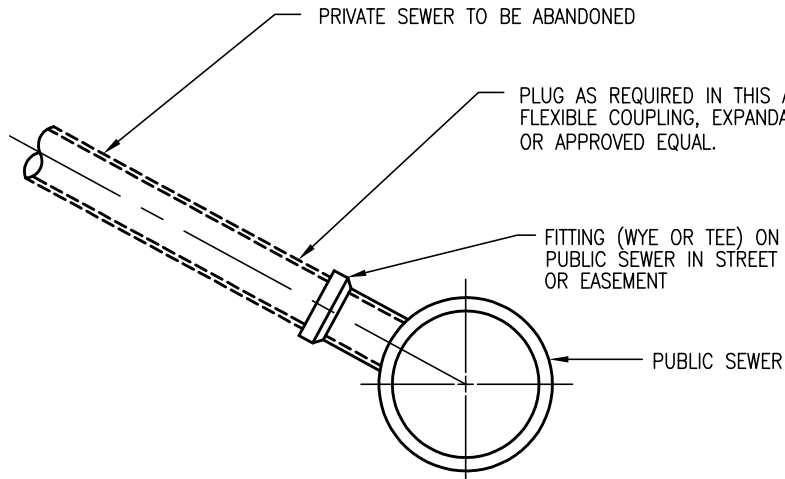

ELEVATION

NOTES:

1. SEWER TAPS ARE NOT CONSIDERED AS A FITTING ON THE PUBLIC SEWER AND MAY REQUIRE REPLACEMENT OF A PORTION OF PUBLIC SEWER FOR DISCONNECTION OF PRIVATE SEWER.
2. "HAMMER TAPS" WILL REQUIRE REPLACEMENT OF A PORTION OF THE PUBLIC SEWER FOR DISCONNECTION OF PRIVATE SEWER.
3. PRIVATE SEWERS CONNECTED TO MAINTENANCE HOLES WILL REQUIRE REMOVAL OF ALL COMPONENTS WITHIN THE MAINTENANCE HOLE AND REPAIR AND RECHANNELIZATION OF MAINTENANCE HOLE AS DIRECTED BY THE ENGINEER.

DATE MARCH 2023 SHEET SD-17
 DRAWN WDH
 APPROVED [Signature]
 DISTRICT ENGINEER, RCE #68475



ORO LOMA SANITARY DISTRICT
 2600 GRANT AVENUE, SAN LORENZO, CA 94580

PRIVATE SEWER
 DISCONNECT
 DETAILS

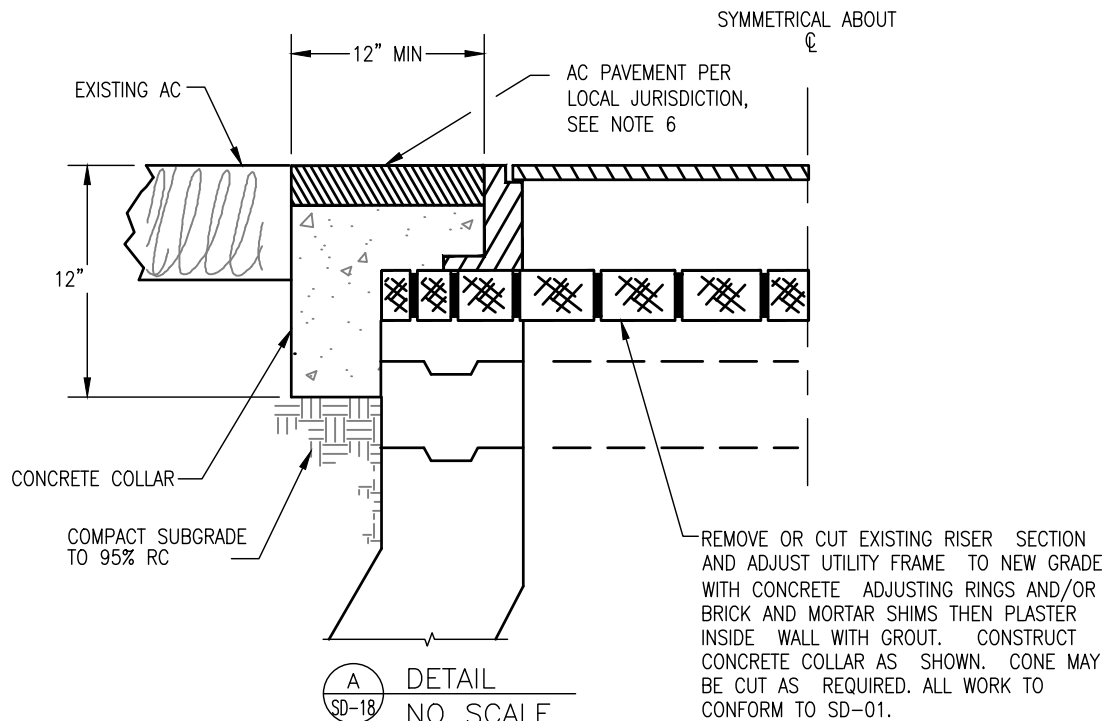
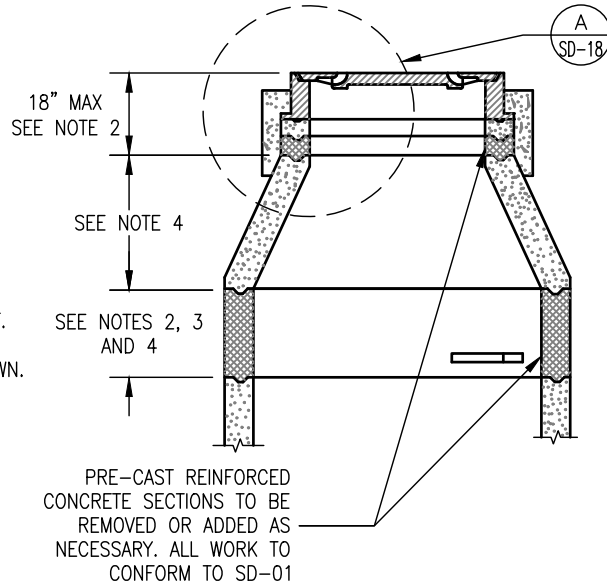
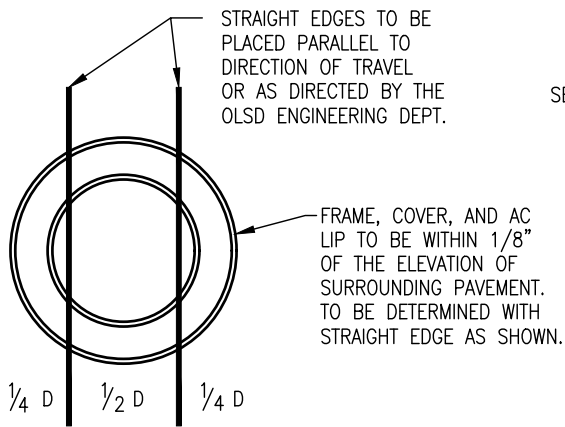

NOTES:

1. FALSE BOTTOM PER SD-21 SHALL BE INSTALLED PRIOR TO ANY WORK.
2. IF NEW GRADE IS TO BE HIGHER THAN EXISTING GRADE, MH THROAT DEPTH SHALL NOT EXCEED 18". ADD SAME DIAMETER BARREL SECTIONS AS NECESSARY WITH NEW MH STEPS AS SHOWN ON STANDARD DETAIL SHEET SD-01.
3. IF NEW GRADE IS TO BE LOWER THAN EXISTING GRADE, REMOVE ADJUSTING RINGS OR SECTIONS OF THE BARREL AND INSTALL COMBINATION OF BARREL SECTION AND ADJUSTING RINGS AS NECESSARY.
4. IF EXISTING ECCENTRIC CONE IS TO BE REMOVED IT SHALL BE REPLACED WITH THE CONCENTRIC TYPE.
5. TRAFFIC CONTROL APPROVAL IS REQUIRED PRIOR TO ANY TRAFFIC LANE OBSTRUCTION. CONTACT LOCAL JURISDICTION FOR PERMITS. ALL COPIES OF PERMITS SHALL BE SUBMITTED TO THE ENGINEER.
6. AC PAVING IS TO CONFORM TO THE STANDARDS OF LOCAL JURISDICTION. PLACE TEMPORARY AC (CUTBACK) AROUND UTILITY FRAME UNTIL PERMANENT PAVING IS PLACED.

DATE MARCH 2023 SHEET SD-18
 DRAWN MPS
 APPROVED [Signature]
 DISTRICT ENGINEER, RCE #68475



ORO LOMA SANITARY DISTRICT
 2600 GRANT AVENUE, SAN LORENZO, CA 94580

MH
 MODIFICATIONS

NOTES:

1. CHANGES IN LAYOUT AND MATERIALS MAY BE ALLOWED WITH OLS D DEPARTMENT OF ENGINEERING APPROVAL.
2. INTERLOCKING BLOCK TO BE 'VERSA-LOK' OR APPROVED EQUAL. BLOCK WALL IS TO BE INSTALLED ACCORDING TO MANUFACTURER'S SPECIFICATIONS. CAP IS TO BE EPOXY GROUTED.

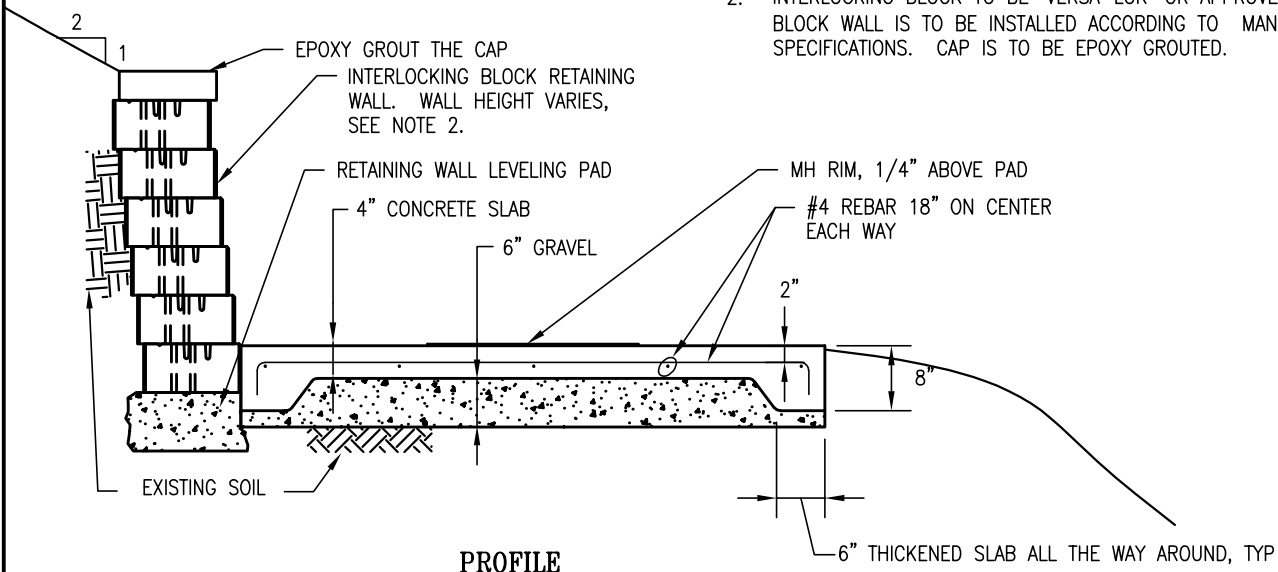

PROFILE

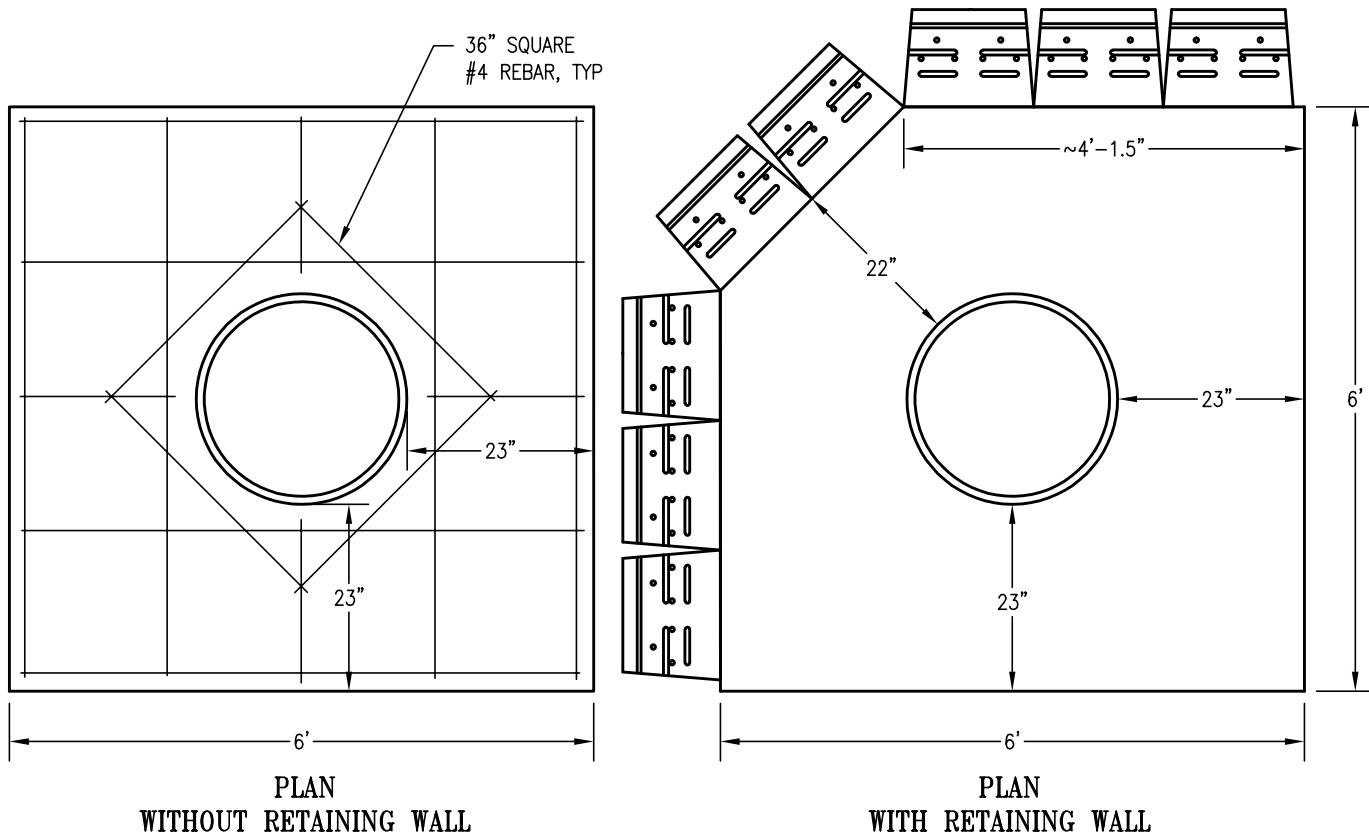

PLAN WITHOUT RETAINING WALL

PLAN WITH RETAINING WALL

DATE MARCH 2023 SHEET SD-19
 DRAWN WDH
 APPROVED [Signature]
 DISTRICT ENGINEER, RCE #68475



ORO LOMA SANITARY DISTRICT
 2600 GRANT AVENUE, SAN LORENZO, CA 94580

MH PAD
 WITH RETAINING
 WALL

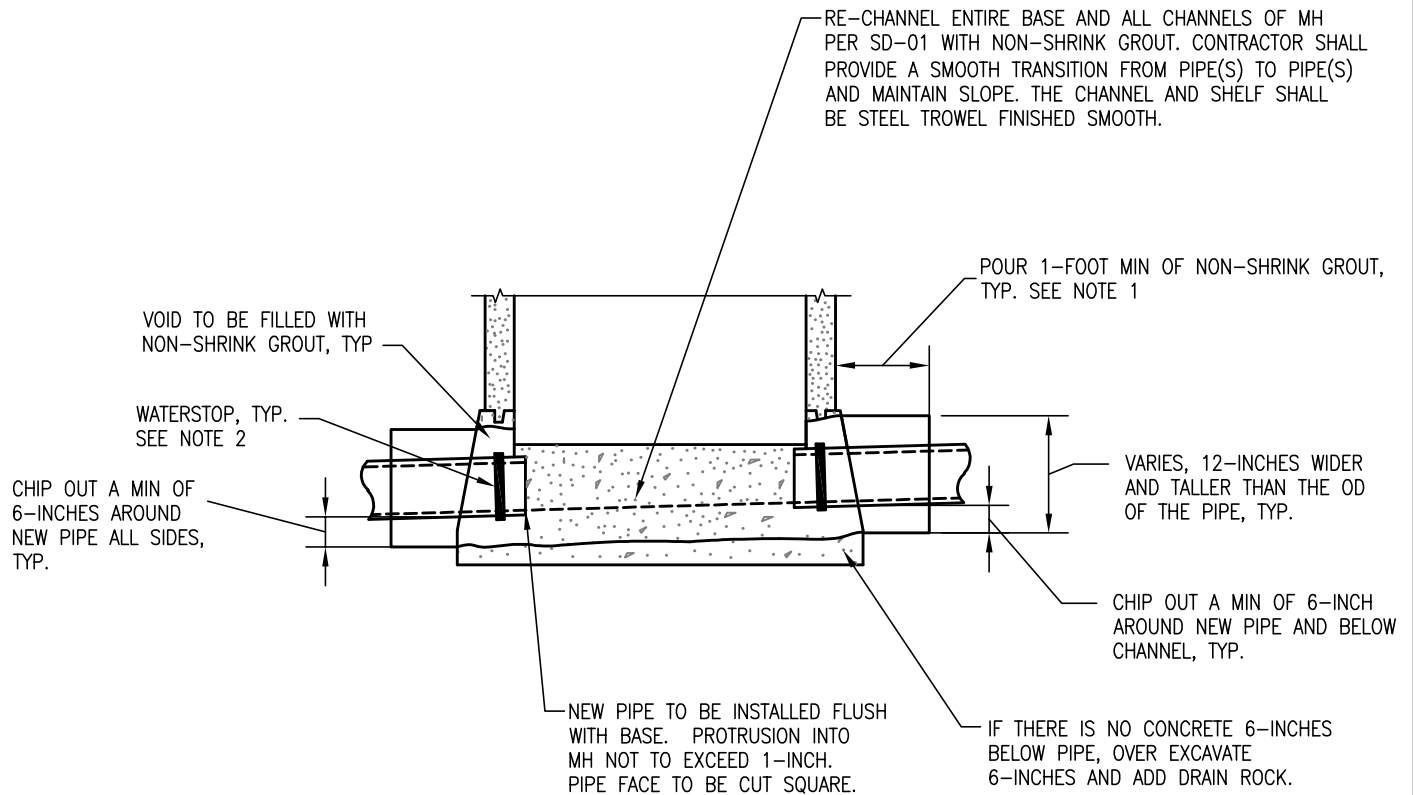

NOTES:

1. CONTRACTOR SHALL OPEN CUT SECTION OF THE PIPE PENETRATION ON THE OUTSIDE OF THE MH TO FORM, POUR AND VIBRATE GROUT. FORMWORK TO BE REMOVED BEFORE BACKFILL.
2. AN APPROVED WATER STOP SHALL BE INSTALLED ON ALL PLASTIC PIPES ENTERING OR LEAVING A MH BASE. THE WATER STOP SHALL BE CENTERED UNDER THE MH OR AS SHOWN.
3. CONTRACTOR SHALL RECONSTRUCT WORK THAT DOES NOT MEET THE STANDARD DETAILS. MH CHANNELS SHALL BE SMOOTH PASSING FLOW FROM PIPE TO PIPE WITHOUT GENERATING TURBULENCE OR CATCHING RAGS AND SOLIDS.

DATE SEPT 2023	SHEET SD-20
DRAWN KMD	
APPROVED <i>[Signature]</i>	
DISTRICT ENGINEER, RCE #68475	



ORO LOMA SANITARY DISTRICT
2600 GRANT AVENUE, SAN LORENZO, CA 94580

PIPE PLACEMENT
THROUGH/INTO
EXISTING MH

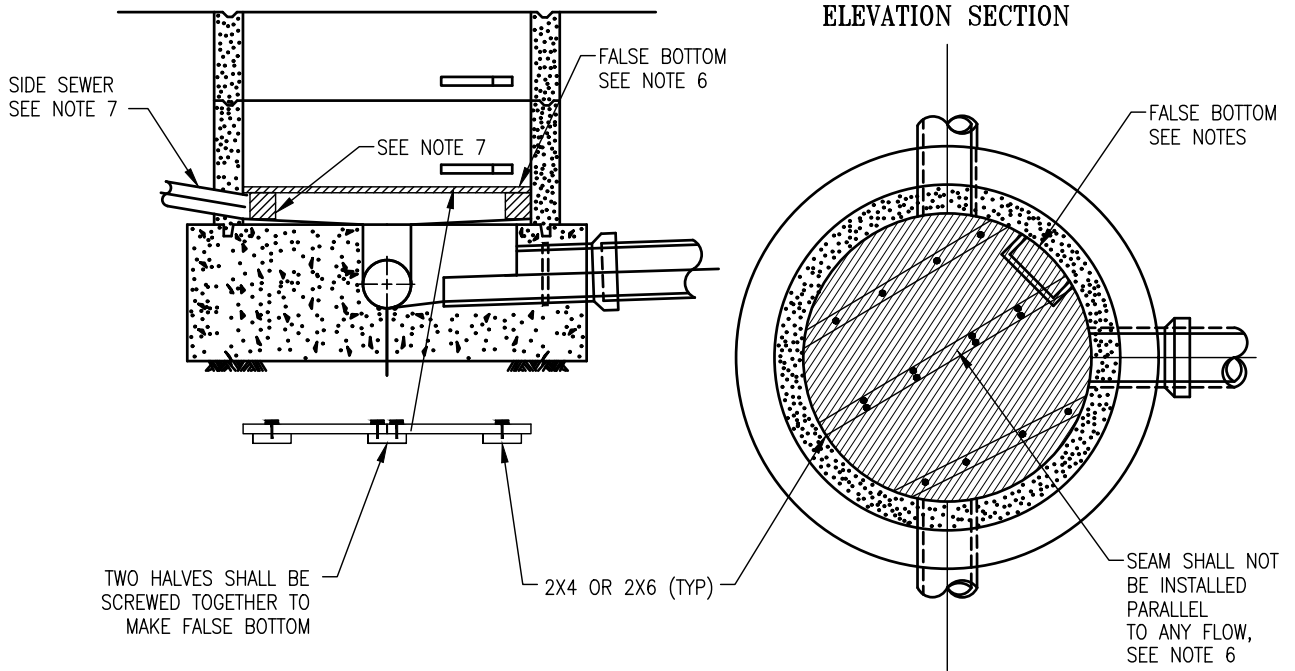

NOTES:

1. CONTRACTOR IS RESPONSIBLE TO FOLLOW ALL SAFETY LAWS INCLUDING CONFINED SPACE ENTRY REQUIREMENTS.
2. FALSE BOTTOMS SHALL NOT BE INSTALLED FOR A PERIOD LONGER THAN 3 WEEKS WITHOUT WRITTEN APPROVAL FROM THE DISTRICT. IN THE EVENT THE FALSE BOTTOMS ARE INSTALLED LONGER THAN THE PERMITTED TIME, IT WILL BE A VIOLATION AND THE DISTRICT WILL REMOVE THE FALSE BOTTOMS AND COMPLETE THE MH WORK AT THE PERMITTEE'S EXPENSE.
3. FALSE BOTTOMS SHALL BE INSTALLED WHEN ANY WORK INSIDE A MH IS TAKING PLACE THAT CAN GENERATE DEBRIS, INCLUDING BUT NOT LIMITED TO LOWERING AND RAISING MHS, PERFORMING REPAIR OR MORTAR WORK, ETC.
4. FALSE BOTTOM INSTALLATION SHALL ONLY TAKE PLACE WITH THE APPROVAL OF THE OLSD ENGINEERING DEPARTMENT AND A PERMIT MUST BE OBTAINED PRIOR TO COMMENCING WORK. PERMIT FEES ARE \$30+\$10 PER MH. A MAP DELINEATING WORK WITH A SCHEDULE SHALL BE SUBMITTED IN ORDER TO OBTAIN A PERMIT. CONTRACTORS FOUND TO BE WORKING ON/IN DISTRICT MHS AND NOT FOLLOWING THIS STANDARD SHALL BE FINED \$1,000.
5. FALSE BOTTOM INSTALLATION MUST BE VERIFIED BEFORE BEGINNING PERMITTED WORK.
6. FALSE BOTTOM IS TO BE CONSTRUCTED OF 1" MARINE GRADE PLYWOOD; NO EXCEPTION. THE PLYWOOD IS TO BE CUT TO A CIRCLE THE DIAMETER OF THE MH BARREL AND THEN CUT IN HALF. THE FALSE BOTTOM IS THEN PLACED IN THE MH WITH THE SEAM CROSSING THE FLOW OR IN SUCH A MANNER TO PROTECT THE SEWER SYSTEM FROM ANY DEBRIS.
7. FALSE BOTTOM IS TO BE PLACED ON BLOCKS AT A MIN OF 1" ABOVE ALL SEWAGE INLETS TO THE MH. FALSE BOTTOM SHALL BE CONNECTED TO THE BLOCKS VIA SCREWS TO PREVENT THE BLOCKS FROM FALLING INTO THE SEWAGE FLOW. ALL COMPONENTS SHALL BE SECURELY FASTENED TOGETHER WITH SCREWS.
8. ALL DEBRIS SHALL BE REMOVED FROM THE MH PRIOR TO THE INSTALLATION OF THE FALSE BOTTOM. THE CONTRACTOR IS RESPONSIBLE FOR THE REMOVAL OF ANY/ALL DEBRIS CREATED DURING THEIR WORK AND SHALL CLEAN OUT THE DEBRIS EACH TIME THE MH IS WORKED ON. DEBRIS SHALL NOT BE LEFT IN THE MH OVERNIGHT.
9. THE CONTRACTOR IS RESPONSIBLE TO REMOVE ALL DEBRIS FROM THE MH AFTER REMOVAL OF THE FALSE BOTTOM. THE CONTRACTOR SHALL CLEAN THE MH SHELF, CHANNEL AND DOWNSTREAM PIPE AS NECESSARY.
10. ANY DAMAGE TO THE SEWER PIPE, OVERFLOWS, BLOCKAGES, OR FAILURES OF FALSE BOTTOMS SHALL BE THE FULL RESPONSIBILITY OF THE AGENCY/CONTRACTOR THAT INSTALLED THE FALSE BOTTOM.
11. IF THERE IS NO SHELF THE CONTRACTOR SHALL SUBMIT ON HOW THE FALSE BOTTOMS ARE TO BE INSTALLED. ALL COMPONENTS SHALL BE SECURELY FASTENED TOGETHER SO THAT AT NO POINT CAN THEY FALL INTO THE FLOW.

DATE SEP 2019 SHEET SD-21
 DRAWN MPS
 APPROVED [Signature]
 DISTRICT ENGINEER, RCE #68475



ORO LOMA SANITARY DISTRICT
 2600 GRANT AVENUE, SAN LORENZO, CA 94580

MH
 FALSE BOTTOM

NOTES:

1. ALL PRE-CAST UNITS SHALL BE MANUFACTURED & TESTED IN ACCORDANCE WITH ASTM C478.
2. INSTALL "RAM-NECK" BETWEEN EACH JOINT OF THE CONE AND BARREL SECTIONS TO MAKE A FLEXIBLE WATER TIGHT JOINT. AFTER JOINT IS MADE, GROUT JOINTS ON THE INSIDE AND OUTSIDE OF MH. AFTER GROUT HAS SET WRAP ALL JOINTS WITH "RUB'R-NEK" JOINT WRAP OR APPROVED EQUAL.
3. AN APPROVED WATER STOP SHALL BE INSTALLED ON ALL PLASTIC PIPES ENTERING OR LEAVING A CAST-IN-PLACE MH BASE BLOCK. THE WATER STOP SHALL BE CENTERED UNDER THE MH WALL OR AS SHOWN.
4. NO STEPS ARE TO BE INSTALLED IN THIS MH.
5. CONSULT DISTRICT REPRESENTATIVE FOR GRIT TRAPS ON SEWERS LARGER THEN 36".

36" MH FRAME AND COVER SEE SD-10

GROUT SHALL BE USED BETWEEN ADJUSTING RINGS

96"x36" CONCENTRIC REDUCER SLAB FOR MHS, TO BE RATED FOR H2O HIGHWAY LOADING

96" PRECAST MH BARREL SECTIONS

USE RAM-NECK OR APPROVED EQUAL, TYP. SEE NOTE 2

USE FORM RING

WATER STOP, TYP SEE NOTE 3

CAST IN PLACE CONCRETE MH BASE BLOCK

#4 REBAR 12" OC EW 2.5 INCHES FROM EDGE OF CONCRETE, REBAR CAGE IS TO BE WIRE TIED TOGETHER, USE CONCRETE 'DOBIES' TO LIFT REBAR CAGE.

48" DIAMETER SUMP TO BE LOCATED DIRECTLY BENEATH THE MH OPENING

REMOVE PIPE THROUGH MH

36" OR SMALLER SEWER, SEE NOTE 5

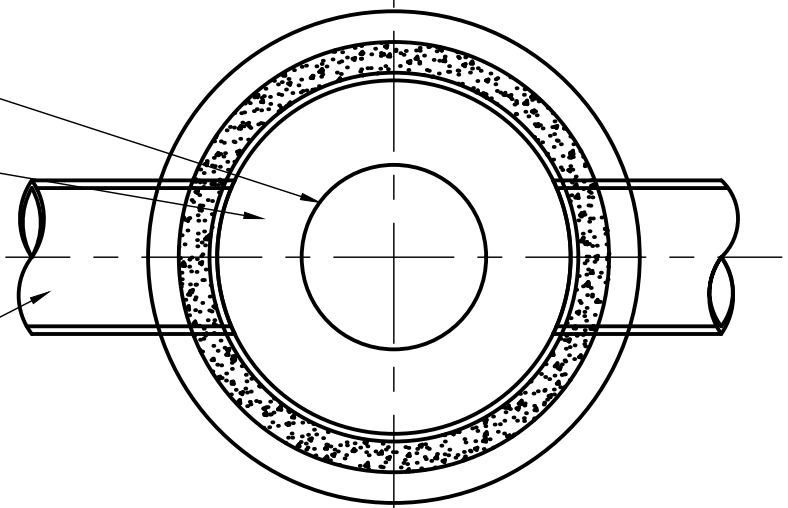
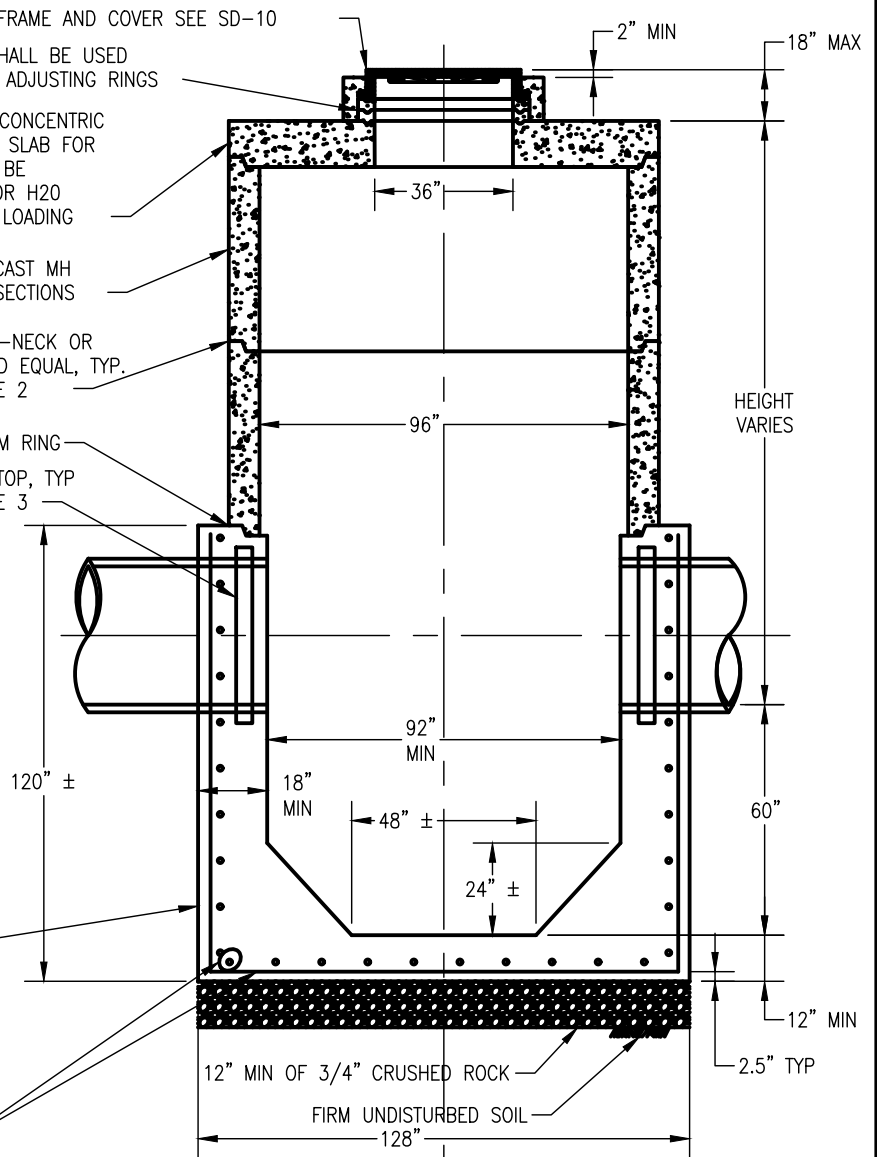

DATE MAY 2006 SHEET SD-22
 DRAWN WDH
 APPROVED [Signature]
 DISTRICT ENGINEER, RCE #68475



ORO LOMA SANITARY DISTRICT

2600 GRANT AVENUE, SAN LORENZO, CA 94580

GRIT TRAP

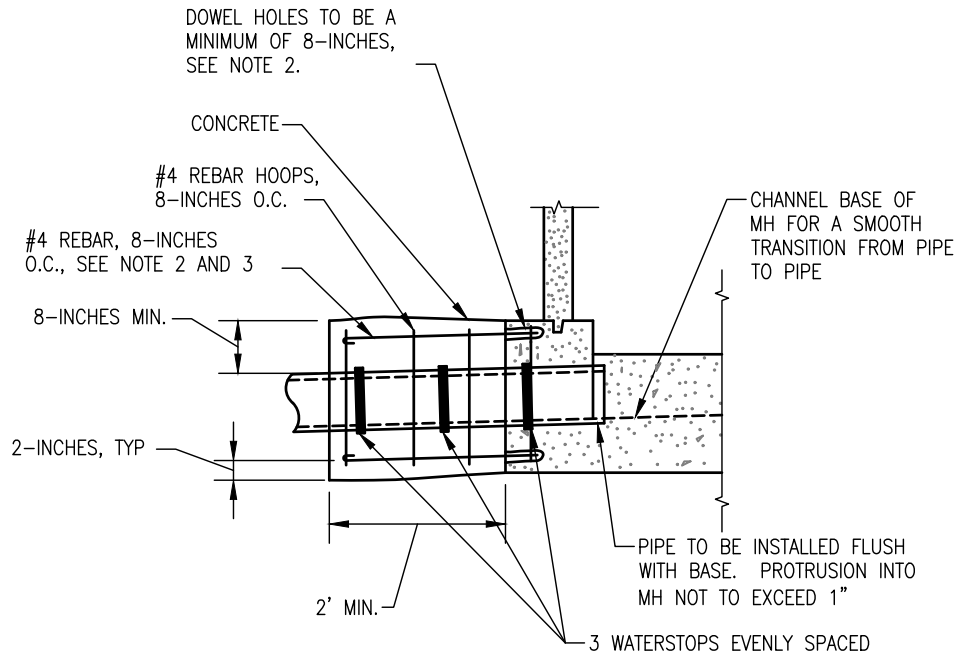

NOTES:

1. REBAR CAGE IS TO BE WIRE TIED TOGETHER.
2. ON RETROFIT MHS REBAR IS TO BE EPOXY DOWELED INTO MH BASE BLOCK A MINIMUM OF 8-INCHES. ON NEW MHS, REBAR, WATERSTOPS, AND PIPE MAY BE PLACED BEFORE POURING THE BASE BLOCK. HORIZONTAL REBAR SHALL BE ONE CONTINUOUS PIECE WITH NO SPLICES. REBAR HOOPS SHALL HAVE A MINIMUM OF 12-INCHES OF OVERLAP.
3. THE HORIZONTAL REBAR SHALL BE HOOKED ONTO THE LAST REBAR HOOP.
4. WATERSTOP PLACEMENT, DOWELING HOLES, AND REBAR CAGE SHALL BE INSPECTED BY THE ENGINEER BEFORE CONCRETE PLACEMENT.

DATE MARCH 2008 SHEET SD-23
 DRAWN WDH
 APPROVED [Signature]
 DISTRICT ENGINEER, RCE #68475



ORO LOMA SANITARY DISTRICT
 2600 GRANT AVENUE, SAN LORENZO, CA 94580

EARTHQUAKE FAULT
 CROSSING MH
 CONNECTION

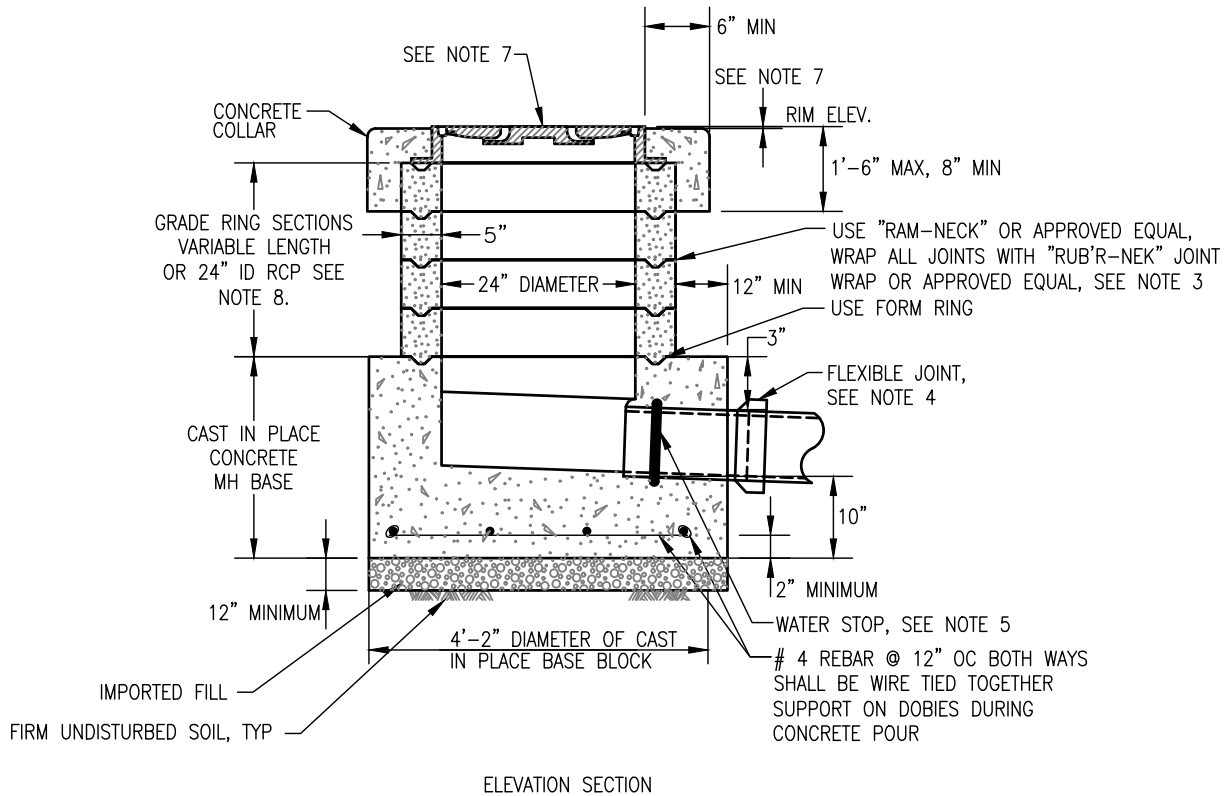

NOTES:

1. 2FT DIAMETER MHS SHALL ONLY BE USED AFTER PRIOR APPROVAL HAS BEEN RECEIVED FROM THE DISTRICT ENGINEER FOR EACH LOCATION TO BE USED.
2. ALL PRE-CAST UNITS SHALL BE MANUFACTURED AND TESTED IN ACCORDANCE WITH ASTM C478.
3. INSTALL "RAM-NECK" BETWEEN EACH JOINT OF THE CONE AND BARREL SECTIONS TO MAKE A FLEXIBLE WATER TIGHT JOINT. AFTER JOINT IS MADE, GROUT JOINTS ON THE INSIDE AND OUTSIDE OF MH. AFTER GROUT HAS SET WRAP ALL OUTSIDE JOINTS WITH "RUB'R-NEK JOINT WRAP OR APPROVED EQUAL.
4. A FLEXIBLE JOINT IS REQUIRED ON 6", 8", 10", & 12" DIAMETER NON-PLASTIC PIPE. THE FLEXIBLE JOINT SHALL BE INSTALLED AS CLOSE AS POSSIBLE TO MH BASE BLOCK (6" MIN., 12" MAX.) TO PROVIDE PIPE FLEXIBILITY.
5. AN APPROVED WATER STOP SHALL BE INSTALLED ON ALL PLASTIC PIPES ENTERING OR LEAVING A MH. THE WATER STOP SHALL BE CENTERED UNDER THE MH WALL OR AS SHOWN.
6. MHS PLACED IN LANDSCAPED AREAS SHALL HAVE A CONCRETE PAD PLACED AROUND THE FRAME AND COVER. THE PAD SHALL BE INSTALLED PER SD-19.
7. 24" CAST IRON OR PLASTIC FRAME AND COVER, SELECTED BY ENGINEER. RIM ELEVATION SHALL BE 1/4" ABOVE CONCRETE COLLAR FOR STEEL FRAME AND COVER. RIM ELEVATION SHALL BE FLUSH WITH CONCRETE COLLAR FOR PLASTIC FRAME AND COVER.
8. 24" RCP PIPE MAY BE USED IN PLACE OF GRADE RINGS. RCP SHALL MEET ASTM-C76 CLASS III.

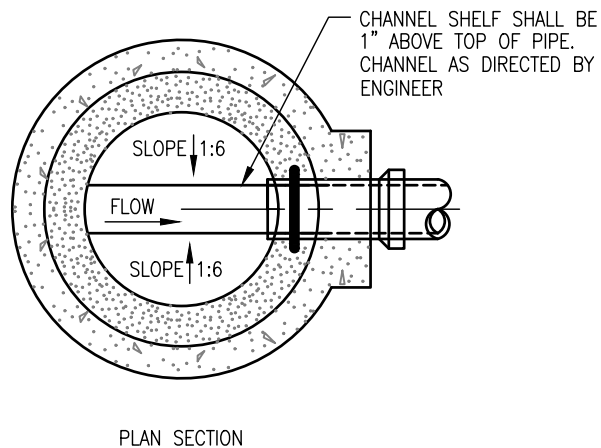

DATE MARCH 2023 SHEET SD-24
 DRAWN KMD
 APPROVED [Signature]
 DISTRICT ENGINEER, RCE #68475



ORO LOMA SANITARY DISTRICT
 2600 GRANT AVENUE, SAN LORENZO, CA 94580

2FT DIAMETER
 MH

CONCRETE PAD
AND SUBGRADE
PER LOCAL
JURISDICTION

REINFORCED CHECKERED PLATE
COVER (H-20 TRAFFIC RATED,
BOLTED DOWN). OLDCASTLE OR
APPROVED EQUAL

ZURN 541 OR APPROVED
EQUAL WITH SEDIMENT
BUCKET

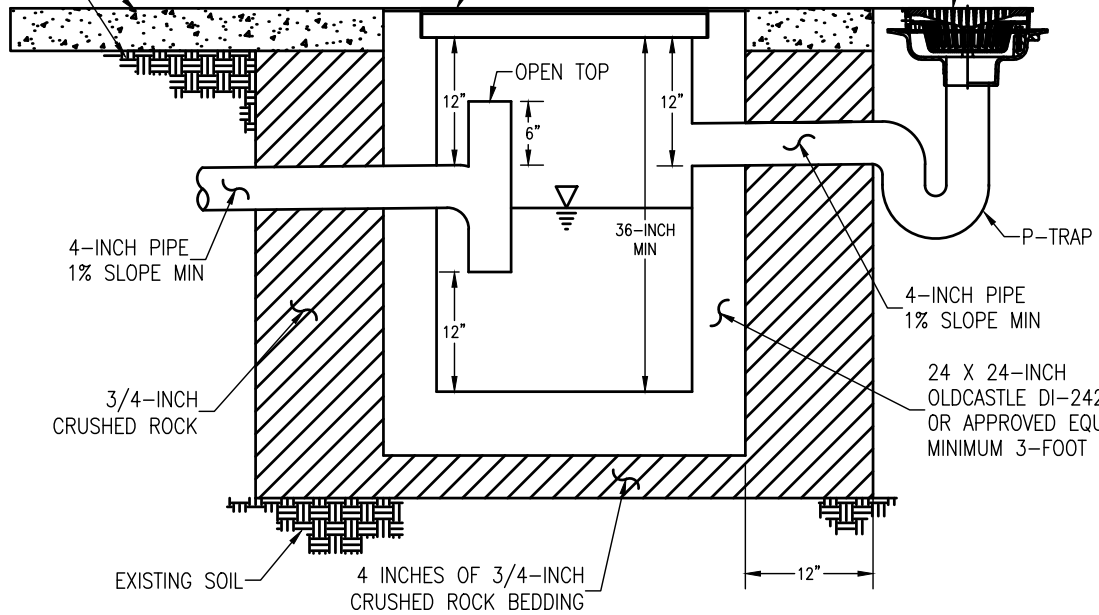

NOTES:

1. GREASE AND SAND TRAP SHALL ONLY BE INSTALLED WITH THE APPROVAL OF THE ENGINEER. TRASH ENCLOSURE DRAIN MAY BE CONNECTED DIRECTLY TO A GREASE INTERCEPTOR.
2. GREASE INTERCEPTORS AND GREASE AND SAND TRAPS ARE PART OF THE PRIVATE SEWER - REPAIR AND MAINTENANCE IS THE RESPONSIBILITY OF THE PROPERTY OWNER.

DATE MAR 2018 SHEET SD-25
DRAWN DAR
APPROVED [Signature]
DISTRICT ENGINEER, RCE #68475



ORO LOMA SANITARY DISTRICT
2600 GRANT AVENUE, SAN LORENZO, CA 94580

TRASH ENCLOSURE
GREASE AND
SAND TRAP